

For the operator

Operating instructions



uniSTOR
domestic hot water cylinder

GB, IE

Table of contents

Inhaltsverzeichnis

1	Notes on the documentation	3
1.1	Other applicable documents	3
1.2	Storing documents	3
1.3	Symbols used.....	3
1.4	Applicability of the instructions.....	3
1.5	Cylinder identification plate.....	3
1.6	CE label	3
1.7	Benchmark	4
2	Safety instructions	4
2.1	Safety and warning information	4
2.1.1	Classification of warnings.....	4
2.1.2	Structure of warnings.....	4
2.2	Intended use	5
2.3	Basic safety instructions.....	5
3	Description of the unit	6
3.1.1	Safety devices.....	6
3.1.2	Hot water temperature regulation	6
3.1.3	Functional elements of cylinder.....	6
4	Operation	7
4.1	Setting the hot water temperature	7
4.2	Using the electric immersion heater	8
4.3	Switching off hot water production	8
4.4	Frost protection.....	8
4.5	Cleaning the cylinder	8
4.6	Temporarily taking the cylinder out of service ...	8
4.7	Energy-saving tips	9
4.8	Fault finding	9
5	Inspection and maintenance	10
6	Recycling and disposal	10
6.1	Disposal of unit.....	10
6.2	Disposal of packaging.....	10
7	Customer service and manufacturer's guarantee	11
7.1	Vaillant service	11
7.2	Vaillant warranty.....	11
8	Technical data	12

1 Notes on the documentation

The following instructions are intended to guide you through the entire documentation.

Further documents apply in combination with these operating instructions.

We do not accept liability for any claims or damages resulting from failure to observe these instructions.

1.1 Other applicable documents

- When operating the cylinder, observe all of the operating instructions delivered with other system components.

These operating instructions are included with the individual components of the system.

1.2 Storing documents

- Store these operating instructions and all other applicable documents in such a way that they are available whenever required.

1.3 Symbols used

The symbols used in the text are explained below.



Symbol that denotes danger:

- Imminent danger to life
- Risk of severe personal injury
- Risk of minor personal injury



Symbol that denotes danger:

- Risk of death from electric shock



Symbol that denotes danger:

- Risk of material damage
- Risk of damage to the environment



Symbol that denotes useful tips and information

- Symbol for a required action

1.4 Applicability of the instructions

These operating instructions are valid exclusively for units with the following article numbers:

Unit type	Cylinder volume	Article number
VIH GB 120/2 S	120 litres	0020115403
VIH GB 155/2 S	155 litres	0020115406
VIH GB 180/2 S	180 litres	0020115409
VIH GB 210/2 S	210 litres	0020115412
VIH GB 260/2 S	260 litres	0020115415
VIH GB 310/2 S	310 litres	0020115418

Table 1.1 Applicability of the instructions

- The article number of the unit is displayed on the identification plate.

1.5 Cylinder identification plate

The identification plate is attached to the front of the cylinder at the factory.

1.6 CE label

CE labelling shows that, based on the type overview, the units comply with the basic requirements of the applicable directives.

- Low voltage directive (Council Directive 2006/95/EC)
- Electromagnetic compatibility directive (Council Directive 2004/108/EC)

2 Safety instructions

1.7 Benchmark



Fig. 1.1 Benchmark logo

Benchmark places responsibilities on both manufacturers and installers. The purpose is to ensure that customers are provided with the correct equipment for their needs, that it is installed, commissioned and serviced in accordance with the manufacturer's instructions by competent persons and that it meets the requirements of the appropriate Building Regulations. The Benchmark Checklist must be used to demonstrate compliance with Building Regulations and must be left with the customer for future reference.

Installers are required to carry out installation, commissioning and servicing work in accordance with the Benchmark Code of Practice which is available from the Heating and Hotwater Industry Council who manage and promote the Scheme.

Visit www.centralheating.co.uk for more information.





2 Safety instructions

2.1 Safety and warning information

When operating the system, observe the basic safety instructions and the warning notes which appear before each of the actions.

2.1.1 Classification of warnings

The warning notes are classified in accordance with the severity of the possible danger using the following warning signs and signal words:

Warning sign	Signal word	Explanation
	Danger!	Imminent danger to life or risk of severe personal injury
	Danger!	Risk of death from electric shock
	Warning!	Risk of minor personal injury
	Caution!	Risk of material or environmental damage

2.1.2 Structure of warnings

Warning signs are identified by an upper and lower separating line and are laid out according to the following basic principle:



Signal word!**Type and source of danger!**

Explanation of the type and source of danger.

- > Measures for averting the danger
-

2.2 Intended use

Vaillant cylinders are constructed using state-of-the-art technology in accordance with recognised safety regulations.

Nevertheless, there is still a risk of injury or danger of death to the operator or others or of damage to the unit and other property in the event of improper use or use for which the unit is not intended.

Vaillant cylinders are not intended for use by persons (including children) with physical, sensory or mental impairments or who have inadequate experience and/or knowledge, unless they are supervised by a person responsible for their safety or have been given instructions by this person regarding the operation of the unit. Children must be supervised to ensure that they do not play with the unit.

Vaillant uniSTOR VIH GB 120/2 S, VIH GB 155/2 S, VIH GB 180/2 S, VIH GB 210/2 S, VIH GB 260/2 S, and VIH GB 310/2 S domestic hot water cylinders are unvented, indirectly heated domestic hot water cylinders designed for use with gas-fired wall-hung boilers as per GB standards for hot water supply systems. The cylinders work with the pressure of the water supply line and do not need a cold water tank for their supply. They are exclusively for the provision of hot potable water to a temperature of 80°C and must be used only for this purpose. The cylinders can be used in combination with a downstream gas-fired wall-hung boiler for hot water production in accordance with GB standards. Any other use or extended use is considered to be improper.

The manufacturer/supplier is not liable for any claims or damage resulting from improper use. The user alone bears the risk.

Complying with the intended use of the unit also includes observing the operating and installation instructions and all other applicable documents and adhering to the inspection and servicing conditions. Improper use of any kind is prohibited!

2.3 Basic safety instructions

Installation, commissioning, and maintenance

Installation and adjustment as well as service, maintenance and repair must be carried out by a competent person approved at the time by the Health and Safety Executive and be in accordance with the relevant requirements of the Local Authority, Building Regulations, Building Regulations (Scotland), Building Regulations (Northern Ireland), and the bye-laws of the local Water Undertaking.

Cylinder safety information

This product has been assessed and found to comply with the requirements of the Building Regulations for unvented hot water storage systems and must not be altered or modified in any way.

- In the event of parts replacement, use only genuine spare parts supplied by Vaillant Ltd.
- You must also observe the guidelines of the local water utility companies.

If the water does not meet the requirements of The Water Supply (Water Quality) Regulations 2000 (Amendment) Regulations 2007, corrosion damage may occur to the cylinder.

- Only use the cylinder to heat potable water.

Preventing frost damage

You should not turn the gas-fired wall-hung boiler off completely so that you can still use all of the safety functions for your heating system. If you want to take the unit out of operation for a relatively long period of time in an unheated room at risk of frost, you must completely drain the cylinder.

Avoiding damage caused by leaks

If there are leaks in the pipework, close off the cold water stop valve on the safety assembly and notify a competent person so that they can rectify the leaks.

Preventing damage due to unauthorised changes to the unit

Changes to the supply lines, relief valve termination, and expansion relief valve may only be carried out by a competent person!

- The installed safety devices must always be used.

Avoiding damage resulting from the closing of the expansion relief valve

Never shut off the expansion relief valve or relief valve termination.

3 Description of the unit

3 Description of the unit

The Vaillant uniSTOR domestic hot water cylinder is available in six sizes: 120, 155, 180, 210, 260 or 310 litres and meets the requirements of EN 12897:2006. The cylinder is made from stainless steel and is insulated with EPS with heat radiation absorbers.

The unvented domestic hot water cylinder works with the pressure of the water supply line and does not need a cold water tank for its supply. To enable the cylinder to work as well as possible, a cold water supply with an appropriate pressure and flow rate is required.

3.1.1 Safety devices

The cylinder is delivered with all safety and control devices for the operation of the unvented domestic hot water supply system:

- Temperature/pressure relief valve (90 °C, 7 bar)
- Pressure reducing valve (3.5 bar) with line strainer
- Expansion relief valve (one-way valve, 6.0 bar)
- Thermal cut-out for electric immersion heater
- Primary heating circuit thermal cut-out.

3.1.2 Hot water temperature regulation

You can set the hot water temperature and primary heating times on the controller. One of the following controllers may be used depending on the design of your system:

Vaillant dual-channel eBUS controller

Cylinder thermostat in conjunction with a timer.

Observe the operating instructions for the installed controller or timer.

Electric immersion heater

The cylinder is equipped with an additional electric immersion heater with a heating output of 3 kW.

The electric immersion heater is designed for use in unvented cylinders and has a thermostat with a temperature controller and a thermal cut-out (TCO) with a reset button.

3.1.3 Functional elements of cylinder

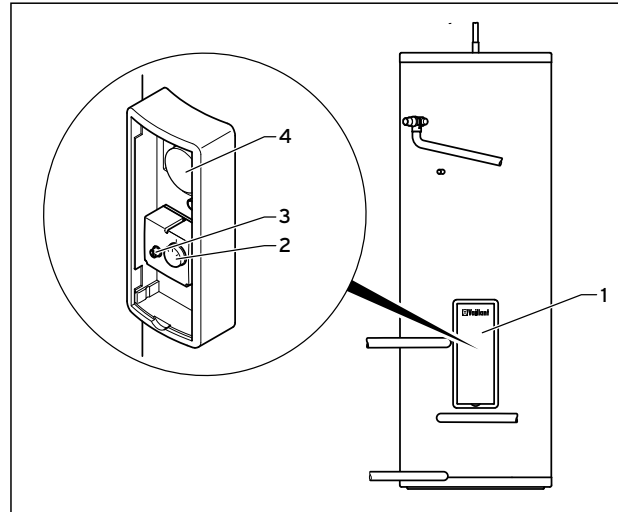

Fig. 3.1 Functional elements of cylinder

Key

- 1 Front cladding
- 2 Cylinder thermostat
- 3 Thermal cut-out
- 4 Electric immersion heater

The following are premounted at the factory for the uniSTOR domestic hot water cylinder:

- Cylinder thermostat (**4**) and primary heating circuit thermal cut-out (**3**)
- Electric immersion heater (**2**) with thermal cut-out and cylinder thermostat

4 Operation



Danger!
Risk of scalding and bursts due to inappropriate alterations!

There is a risk of escaping steam, bursting, and damage to the system if you make any changes to the cylinder, control system, supply lines for water and power (if present), relief valve termination, or expansion relief valve for the cylinder water.

- Do not make any improper changes.



Warning!
Risk of scalding

The output temperature of the draw-off points can reach 85 °C if the mixing valve is set incorrectly.

- Do not adjust the mixing valve.
- If the output temperature at the draw-off point is too high or low, contact a competent person to set the output temperature.



Caution!
Risk of damage from leaks!

Leaks in the water pipes between the cylinder and tap can result in water damage.

- If a leak occurs, close the cold water stop valve on the cylinder.
- Contact a competent person to eliminate the leak.

The cold water stop valve is located in the pipe connection of your domestic water connection for the cylinder (cold water connection) which should have been fitted by your installer in an accessible position close to the cylinder.

4.1 Setting the hot water temperature

The hot water temperature is set to the required value by the competent person during cylinder commissioning.

If an external controller is installed for hot water temperature control, you can set the hot water temperature and primary heating times using this controller. For information on making settings, see the operating instructions for the controller

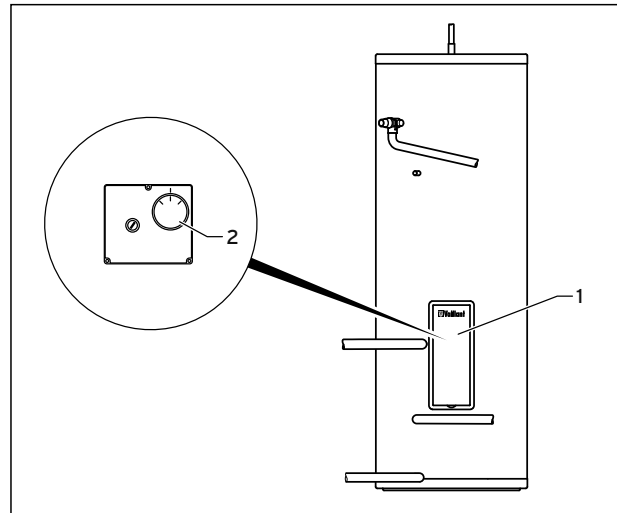

Fig. 4.1 Setting the cylinder thermostat

Key

- 1 Front cladding
- 2 Cylinder thermostat

If no controller for hot water temperature control is installed, you can set the required hot water temperature on the cylinder thermostat (2). You can set the reheating times on the installed timer. Observe the operating instructions for the timer.

- Remove the front cladding (1) from the cylinder.
- Set the desired cylinder hot water temperature on the cylinder thermostat (2).
- Mount the upper front cladding on the cylinder. In order to avoid calcification, the temperature should be set to a maximum of 60 °C.
- Use the operating instructions for the gas-fired wall-hung boiler to make sure that the unit is ready for operation.

4 Operation



If you are heating up water for the first time or after a long switch-off period, the full cylinder performance is only available following a waiting period.



If the uniSTOR has been installed in a cupboard used for airing clothes, make sure that clothing and other objects are not placed on the cylinder, control devices, pipes or other system components.



Always make sure that there is clear access to the cylinder to enable the use of the hot water thermostat controller and the thermostat mixer.

4.2 Using the electric immersion heater

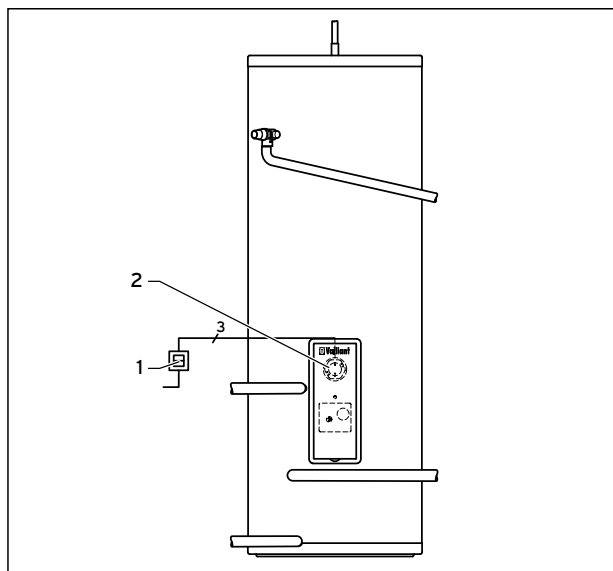

Fig. 4.2 Using the electric immersion heater

Key

- 1 Switch
- 2 Electric immersion heater

The electric immersion heater (2) should only heat the water if the gas-fired wall-hung boiler fails. The electric immersion heater may not be operated at the same time as the gas-fired wall-hung boiler.

- If the gas-fired wall-hung boiler fails, switch the electric immersion heater on using the switch (1).
- Once the gas-fired wall-hung boiler is in service again, use the switch to switch the electric immersion heater off.

4.3 Switching off hot water production

- Switch off the gas-fired wall-hung boiler (see operating instructions for the gas-fired wall-hung boiler) to temporarily switch off the heating and hot water system.

4.4 Frost protection



Caution!

Risk of damage due to frost!

If the cylinder is placed out of operation for a relatively long period of time in an unheated room (e.g. during a winter holiday), the cylinder must be completely drained.

- Contact a competent person to drain the cylinder.

If you are absent during a relatively long period when there is a risk of frost, make sure that you leave the central heating on and that the temperature in the cylinder room and in all other rooms is kept above freezing.

4.5 Cleaning the cylinder

- Clean the outside of the cylinder only with a damp cloth, using soapy water if it is especially dirty. Do not use abrasive cleaning agents or solvents (any type of scouring agent, petroleum etc.) since they can damage the cladding and the cylinder fixtures.

4.6 Temporarily taking the cylinder out of service



Caution!

Risk of damage as a result of the cylinder freezing!

Frost protection and monitoring devices are only active while the boiler is connected up to the power supply.

- Make sure that the cylinder cannot be damaged if there is a frost.

- Temporarily take the cylinder out of service by switching the boiler off.

4.7 Energy-saving tips

Appropriate hot water temperature

The warm water should only be heated up to the extent that is necessary for use. Any further heating results in unnecessary power consumption and hot water temperatures of more than 60°C also lead to increased lime scale production.

Run circulation pumps only if needed

Circulation pumps do indeed increase convenience when it comes to hot water production. But they also need power. And circulating hot water that is not used cools off when passing through pipes and then needs to be reheated. Therefore, circulation pumps are to be operated only when hot water is actually needed for the household. Individual timer programs can be set using autotimers which are already installed or can be retrofitted in most circulation pumps. Weather compensators often have ancillary functions for controlling circulation pump timings. Consult your heating specialist company.

4.8 Fault finding

What do I do if ...

Fault	Remedy
... fluid is dripping from the system?	If possible, collect the fluid in a bucket and inform a competent person.
... the controller issues a message telling me the sensor is faulty or there is a cable break?	Inform a competent person.
... the cylinder is not providing sufficient hot water?	Check that the hot water temperature is set correctly on the controller (→ section 4.1 , recommended value of approx. 45°C) and that the gas-fired wall-hung boiler is working. If the settings are correct, the cylinder may be calcified. Then: Inform a competent person.
... a thermal cut-out trips?	Inform a competent person.
... water flows from the expansion relief valve?	Inform a competent person.

Tab. 4.1 Troubleshooting by the operator

5 Inspection and maintenance

6 Recycling and disposal

5 Inspection and maintenance

An annual inspection/maintenance carried out by a competent person is a prerequisite for ensuring that the cylinder is permanently ready for operation, reliable, and has a long working life.

It is important that your hot water cylinder is serviced annually.

We recommend entering into a maintenance agreement.



Danger!

Risk of death from electric shock!

Improperly executed work on the cylinder can result in a risk to life and limb.

- Never try to rectify cylinder faults yourself.
- Contact a competent person to rectify all faults.



Danger!

Risk of injury resulting from improper maintenance or repair.

Failure to arrange for the system to be maintained and repaired and improper maintenance and repair can impair the operational safety of the unit, leading to personal injury and material damage.

- Never attempt to perform maintenance work or repairs on the cylinder yourself.
 - Always employ a competent person.
-

6 Recycling and disposal

Both the Vaillant cylinder and its transport packaging consist mainly of recyclable raw materials.

6.1 Disposal of unit

You must not dispose of your Vaillant cylinder or any of its accessories in normal domestic rubbish. Make sure that the old unit and any accessories are disposed of properly.

6.2 Disposal of packaging

Arrange for the competent person who installed the unit to dispose of the transport packaging.

7 Customer service and manufacturer's guarantee

7.1 Vaillant service

To ensure regular servicing, it is strongly recommended that arrangements are made for a Maintenance Agreement. Please contact Vaillant Service Solutions (0870 6060 777) for further details.

7.2 Vaillant warranty

Vaillant provides a full parts and labour warranty for this appliance.

The appliance and all associated pipe work and controls must be installed by suitably competent persons in accordance with all current and relevant safety, building control and planning regulations and in full compliance with the manufacturer's instructions.

All unvented domestic hot water cylinders must be installed by a competent person to the prevailing building regulations at the time of installation (G3).

Terms and conditions apply to the warranty, details of which can be found on the warranty registration card included with this appliance.

Failure to install and commission this appliance in compliance with the manufacturer's instructions may invalidate the warranty (this does not affect the customer's statutory rights).

8 Technical data

8 Technical data

	Unit	VIH GB 120/2 S	VIH GB 155/2 S	VIH GB 180/2 S	VIH GB 210/2 S	VIH GB 260/2 S	VIH GB 310/2 S
Total capacity	litres	120	155	180	210	260	310
Actual capacity	litres	119,2	149,1	176,6	211,2	250,3	298,5
Hot water capacity	litres	104,0	136,7	166,4	203,9	247,5	270,5
Maximum supply pressure to pressure reducing valve	MPa (bar)	1,2 (12)					
Rated pressure of cylinder	MPa (bar)	0,7 (7)					
Maximum operating pressure of heating coil	MPa (bar)	0,35 (3,5)					
Operating pressure	MPa (bar)	0,35 (3,5)					
Pressure reducing valve	MPa (bar)	0,35 (3,5)					
Expansion relief valve	MPa (bar)	0,6 (6)					
Temperature and pressure relief valve	°C, MPa (bar)	90, 0,7 (7)					
Charge pressure of hot water expansion vessel	MPa (bar)	0,4 (4)					
Maximum temperature of heating circuit	°C	85					
Maximum temperature of potable hot water	°C	85					
Standing heat loss	kW/24 h	1,26	1,53	1,66	1,89	2,07	2,26
Heat up time according to EN 12897	mins	18	23	24	28	35	42
Recovery time (70% capacity)	mins	16	18	17	20	25	30
Primary heat exchanger performance	kW	18,6	18,8	22,0	22,6	22,3	20,4
Flow rate for primary heat exchanger performance	l/min	23,3					
Primary heat exchanger pressure drop	mbar	97	97	116	116	116	115
Primary heat exchanger volume	litres	2,94	2,94	3,56	3,56	3,56	3,56
Primary heat exchanger surface area	m ²	0,62	0,62	0,75	0,75	0,75	0,75
Dimensions							
Height	mm	1001	1191	1371	1593	1843	2153
Height with hot water draw off	mm	1033	1223	1403	1625	1875	2185
Topple measure	mm	1138	1308	1473	1680	1918	2217
Diameter	mm	554,5					
Depth	mm	633					
Net weight	kg	26	29	32	36	41	46
Weight (full)	kg	145	177,8	209	248	291	345
Connections							
Cold water inlet		22 mm unprofiled pipe (crimp joints)					
Hot water draw off		22 mm unprofiled pipe (crimp joints)					
Pressure-controlled cold water inlet		22 mm unprofiled pipe (crimp joints)					
Secondary return		15 mm unprofiled pipe (crimp joints)					
Primary heater flow		22 mm unprofiled pipe (crimp joints)					
Primary heater return		22 mm unprofiled pipe (crimp joints)					
Primary heating circuit immersion sleeve size	mm	8					
Electrical connections							
Immersion heater (according to ENBS 60335)		2.7 kW, 230 V, 50 Hz					
Length of immersion heater	inch	14					
Two port motorised valve		230/240 V, 50 Hz					
Cylinder thermostat		230/240 V, 50 Hz					
Material data							
Cylinder body material		Stainless steel (1.4521)					
Cylinder jacket material		Polypropylene					
Insulation material		EPS with heat radiation absorber					
Insulation thickness	mm	50					
Corrosion protection		Stainless steel					
Blowing agent for insulation material		Pentane (GWP < 5)					
ODP		0					

Tab. 3.1 Technical data for uniSTOR domestic hot water cylinder



The heat up time is based on a flow rate of 1400 l/h at 80 °C.
Temperature rise from 15 °C to 60 °C.

Supplier

Vaillant Ltd

Vaillant House ■ Medway City Estate ■ Trident Close ■ Rochester ■ Kent ME2 4EZ
Telephone 01634 292300 ■ Fax 01634 290166 ■ www.vaillant.co.uk ■ info@vaillant.co.uk

Manufacturer

Vaillant GmbH

Berghauser Str. 40 ■ D-42859 Remscheid ■ Telefon 0 21 91/18-0
Telefax 0 21 91/18-28 10 ■ www.vaillant.de ■ info@vaillant.de

For the competent person

Installation and maintenance instructions



uniSTOR
VIH /2 S

GB, IE

Table of contents

Inhaltsverzeichnis

1	Notes on the documentation	3	6	Commissioning	28
1.1	Other applicable documents	3	6.1	Flushing the reheating circuit	28
1.2	Storing documents	3	6.2	Water treatment.....	28
1.3	Symbols used.....	3	6.3	Filling the cylinder.....	29
1.4	Applicability of the instructions.....	3	6.4	Filling the central heating system	30
1.5	Cylinder identification plate.....	3	6.5	Commissioning the gas-fired wall-hung boiler ..	31
1.6	CE label	3	6.6	Filling in the cylinder commissioning checklist..	31
1.7	Benchmark	4	6.7	Handover to the operator.....	31
2	Safety instructions and regulations	4	7	Inspection and maintenance	32
2.1	Safety and warning information	4	7.1	Checking the temperature and pressure relief valve and expansion relief valve.....	32
2.1.1	Classification of warnings.....	4	7.2	Checking the charge pressure of the expansion vessel.....	32
2.1.2	Structure of warnings.....	4	7.3	Draining the cylinder	32
2.2	Intended use	5	8	Fault finding	33
2.3	General safety instructions	5	9	Taking the cylinder out of service	35
2.4	Overview of EU standards	6	9.1	Temporarily taking the cylinder out of service.....	35
2.5	Regulations for Great Britain.....	7	9.2	Permanently taking the cylinder out of service.....	35
2.5.1	Technical Guidance.....	7	10	Recycling and disposal	35
2.5.2	Related documents.....	7	10.1	Cylinder disposal.....	35
3	Description of the unit	8	10.2	Disposal of packaging.....	35
3.1	Description of the cylinder	8	11	Customer service and manufacturer's guarantee	36
3.1.1	Safety devices.....	10	11.1	Vaillant service	36
3.1.2	Cylinder operating elements.....	10	11.2	Vaillant warranty.....	36
3.1.3	Electric immersion heater	11			
3.1.5	Wiring.....	11			
3.1.6	Combination of uniSTOR domestic hot water cylinder and controllers	11			
3.2	Technical data.....	12			
4	Assembly	14			
4.1	Scope of delivery	14			
4.2	Transporting the cylinder	14			
4.3	Installation site.....	14			
5	Installation	15			
5.1	Installing pipes for the reheating circuit.....	15			
5.2	Installing hot water pipes	16			
5.3	Installation of cold mains inlet	16			
5.3.1	Pressure in cold mains inlet	16			
5.3.2	Mounting the safety assembly	17			
5.3.3	Mounting the expansion vessel	17			
5.3.4	Mounting the drain valve	18			
5.3.5	Laying the pipes to the tundish	18			
5.4	Installation of discharge pipe	18			
5.4.1	Design of discharge pipe.....	18			
5.4.2	High drain	19			
5.5	Electrical installation	20			
5.5.1	Electrical connection of control components...	20			
5.5.2	Connecting up the electric immersion heater....	21			
5.5.3	Options for combining control components	22			
5.5.4	Installing the control components in accordance with the connection wiring diagrams.....	24			

1 Notes on the documentation

The following instructions are intended to guide you through the entire documentation. Other documents apply in addition to these operating instructions. We do not accept liability for any claims or damages resulting from failure to observe these instructions.

1.1 Other applicable documents

- ▶ When installing the cylinder, you must pay attention to the installation instructions for components of the system.

These installation instructions are enclosed with the various system components as well as additional components.

- ▶ You must also observe all operating instructions included with the system components.

1.2 Storing documents

- ▶ Pass these installation instructions and all other applicable documents and, if necessary, any required tools to the system operator.

The system operator will store these so that they are available when required.

1.3 Symbols used

The symbols used in the text are explained below.



Symbol that denotes danger:

- Imminent danger to life
- Risk of severe personal injury
- Risk of minor personal injury



Symbol that denotes danger:

- Risk of death from electric shock



Symbol that denotes danger:

- Risk of material damage
- Risk of damage to the environment



Symbol that denotes useful tips and information

- ▶ Symbol for a required action

1.4 Applicability of the instructions

These installation instructions are valid exclusively for units with the following article numbers:

Unit type	Cylinder volume	Article number
VIH GB 120/2 S	120 litres	0020115403
VIH GB 155/2 S	155 litres	0020115406
VIH GB 180/2 S	180 litres	0020115409
VIH GB 210/2 S	210 litres	0020115412
VIH GB 260/2 S	260 litres	0020115415
VIH GB 310/2 S	310 litres	0020115418

Table 1.1 Applicability of the instructions

- ▶ The article number of the unit is displayed on the identification plate.

1.5 Cylinder identification plate

The identification plate is attached to the front of the cylinder at the factory.

1.6 CE label

CE labelling shows that, based on the type overview, the units comply with the basic requirements of the following directives:

- Low voltage directive (Council Directive 2006/95/EC)
- Electromagnetic compatibility directive (Council Directive 2004/108/EC)

1 Notes on the documentation

2 Safety instructions and regulations

1.7 Benchmark



Fig. 1.1 Benchmark logo

Benchmark places responsibilities on both manufacturers and installers. The purpose is to ensure that customers are provided with the correct equipment for their needs, that it is installed, commissioned and serviced in accordance with the manufacturer's instructions by competent persons and that it meets the requirements of the appropriate Building Regulations. The Benchmark Checklist can be used to demonstrate compliance with Building Regulations and should be provided to the customer for future reference. Installers are required to carry out installation, commissioning and servicing work in accordance with the Benchmark Code of Practice which is available from the Heating and Hotwater Industry Council who manage and promote the Scheme. Visit www.centralheating.co.uk for more information.





2 Safety instructions and regulations

2.1 Safety and warning information

When conducting installation and maintenance work, observe the general safety instructions and the warning notes which appear before each of the actions.

2.1.1 Classification of warnings

The warning notes are classified in accordance with the severity of the possible danger using the following warning signs and signal words:

Warning sign	Signal word	Explanation
	Danger!	Imminent danger to life or risk of severe personal injury
	Danger!	Risk of death from electric shock
	Warning!	Risk of minor personal injury
	Caution!	Risk of material or environmental damage

2.1.2 Structure of warnings

Warning signs are identified by an upper and lower separating line and are laid out according to the following basic principle:

	<p>Signal word!</p> <p>Type and source of danger!</p> <p>Explanation of the type and source of danger.</p> <ul style="list-style-type: none"> > Measures for averting the danger
---	--

2.2 Intended use

Vaillant cylinders are constructed using state-of-the-art technology in accordance with recognised safety regulations.

Nevertheless, there is still a risk of injury or danger of death to the operator or others or of damage to the unit and other property in the event of improper use or use for which the unit is not intended.

Vaillant-cylinders are not intended for use by persons (including children) with physical, sensory or mental impairments or who have inadequate experience and/or knowledge, unless they are supervised by a person responsible for their safety or have been given instructions by this person regarding the operation of the unit. Children must be supervised to ensure that they do not play with the unit.

Vaillant uniSTOR VIH GB 120/2 S, VIH GB 155/2 S, VIH GB 180/2 S, VIH GB 210/2 S, VIH GB 260/2 S, and VIH GB 310/2 S domestic hot water cylinders are unvented, indirectly heated domestic hot water cylinders designed for use with gas-fired wall-hung boilers as per GB standards for hot water supply systems. The cylinders work with the pressure of the water supply line and do not need a cold water tank for their supply. They are exclusively for the provision of hot potable water to a temperature of 80°C. They may only be used for this purpose. The cylinders can be used in combination with a gas-fired wall-hung boiler for hot water production in accordance with GB standards.

Any other use or extended use is considered to be improper. Any direct commercial or industrial use is also deemed to be improper.

The manufacturer/supplier is not liable for any claims or damage resulting from improper use. The user alone bears the risk.

Complying with the intended use of the unit also includes observing the operating and installation instructions and all other applicable documents and adhering to the inspection and servicing conditions. Improper use of any kind is prohibited!

At the end of these instructions there is a commissioning report which you must fill in and hand over to the operator.

All installers should have a current ID card and registration number. The cylinder must be installed by a competent person approved at the time by the Health and Safety Executive to the prevailing standards, installation book and building regulations at the time of installation.

2.3 General safety instructions

Installation, commissioning-up, and maintenance

Installation and adjustment as well as service, maintenance and repair must be carried out by a competent person approved at the time by the Health and Safety Executive and be in accordance with the relevant requirements of the Local Authority, Building Regulations, Building Regulations (Scotland), Building Regulations (Northern Ireland), and the bye-laws of the local Water Undertaking.

All electrical wiring must be carried out by a competent electrician and be in accordance with the current I.E.E. Wiring Regulations.

- ▶ Make sure that the system has been planned in accordance with technical regulations and all applicable planning standards.

Cylinder safety information

Following an inspection, it was ascertained that this product complies with the building regulations for closed hot water cylinder systems and must not be changed or rebuilt in any way.

- ▶ When replacing parts, only original replacement parts from Vaillant Ltd. may be used.

The installation must be approved in accordance with the building regulations.

- ▶ Installation plans must be disclosed to the relevant authorities.

Important:

As stipulated in the manual "Handling Operations Regulations 1992", the weight of the unit exceeds that which should be lifted by one person alone.

Prior to assembly, store the cylinder in an upright position in a dry place.

Without potential equalisation, life-threatening voltage from the electric immersion heater can reach the piping and water taps.

- ▶ Earth the electric immersion heater.

If the domestic hot water cylinder is connected with pipes made of non-metallic materials and is not earthed, corrosion damage can occur.

- ▶ Earth the domestic hot water cylinder for potential equalisation and to protect against overvoltage.
- ▶ If using non-metallic pipes in the water circuit, make sure that they are designed by the manufacturer for continuous operation at 70°C and operation by the hour at temperatures of up to 95°C.
- ▶ Always use a suitable open-end wrench (spanner) to tighten or undo threaded connections. Do not use pipe wrenches, extensions, etc.

2 Safety instructions and regulations

If the water does not meet the requirements of The Water Supply (Water Quality) Regulations 2000 (Amendment) Regulations 2007, corrosion damage may occur on the cylinder.

- Only use the cylinder to heat potable water.

Electric potential equalisation

If you use an electric immersion heater in the cylinder, the external voltage may build up electrical potential in the water which can result in the electrochemical corrosion of the electric immersion heater.

- Make sure that both the hot water and cold mains inlets on the cylinder itself are connected to the earth line by means of an earth cable.
- You must also make sure that the electric immersion heater is connected to the earth line via the earthing terminal.

Preventing frost damage

You should not turn the gas-fired wall-hung boiler off completely so that you can still use all of the safety functions for your heating system. If you want to take the unit out of operation for a relatively long period of time in an unheated room at risk from frost, you must completely drain the cylinder.

Avoiding damage caused by leaks

If there are leaks in the pipework, close off the cold water stop valve on the safety assembly and notify a competent person to rectify the leaks.

Preventing damage due to unauthorised changes to the unit

Changes to the supply lines, relief valve termination, and expansion relief valve may only be carried out by a competent person!

Avoiding burns and scalds

Install a hot water thermostat mixer in the system to protect against scalding.

2.4 Overview of EU standards

Pressure equipment directive 97/23/EC

Directive of the European Parliament and Council of 29th May 1997 for the approximation of the laws on pressure equipment of the Member States

EN 12897:2006

Water supply - specification for indirectly heated unvented (closed) domestic hot water cylinders

EN 806-1

Specifications for installations inside buildings conveying water for human consumption - Part 1: General

EN 1717

Protection against pollution of potable water installations and general requirements of devices to prevent pollution by backflow

EN 60335-1

Safety of household and similar electrical appliances; Part 1: General principles (IEC 60335-1: 2001, modified)

EN 60335-2-21

Safety of household and similar electrical appliances; Part 2: Particular requirements for storage water heaters (domestic hot water cylinders and hot water boilers) (IEC 335-2-21: 1989 and supplements 1; 1990 and 2; 1990, modified)

EN 60335-2-73

Safety of household and similar electrical appliances; Part 2: Particular requirements for fixed immersion heaters (IEC 335-2-73: 1994, modified)

EN 60529

Degrees of protection provided by casing (IP code) - (IEC 60529: 1989 + A1: 1999)

EN 60529-1

Degrees of protection provided by casing (IP code) - (IEC 60529: 1989 + A1: 1999)

EN 60730-1

Automatic Electrical Controls for Household and Similar Use - Part 1: General requirements (IEC 60730-1: 1999, modified)

EN 60730-2-9

Automatic Electrical Controls for Household and Similar Use - Part 2-9: Particular requirements for temperature-sensing controls (IEC 60730-2-9: 2000, modified)

Directive 2004/108/EC

Directive 2004/108/EC of the European Parliament and Council of 15th December 2004 on the approximation of the laws of the Member States relating to electromagnetic compatibility and repealing Directive 89/336/EEC

EC low voltage directive 2006/95/EC

Directive 2006/95/EC of the European Parliament and Council of 12th December 2006 on the harmonisation of the laws of Member States relating to electrical equipment designed for use within certain voltage limits

Lightning protection

ENV 61024-1

Protection of structures against lightning - Part 1: General principles (IEC 1024-1: 1990; modified) BS 6651: Code of practice for protection of structures against lightning

2.5 Regulations for Great Britain

2.5.1 Technical Guidance

This appliance must only be installed and commissioned by a suitably competent person. Please check with your installer that he is able to carry-out all the necessary works including official notification of the works to the relevant body upon completion.

The system must be installed in accordance with all relevant and applicable national regulations, and must be installed to suit site conditions.

Observe all national regulations, including:

- Working at Heights Regulations 2005
- Health and Safety at Work Act 1974
- Electricity at Work Regulations 1989
- IEE Wiring Regulations BS 7671
- Lightning protection requirements
- Equipotential bonding of electrical installations.

2.5.2 Related documents

The installation of the appliance and any associated hot water system must be in accordance with (but not limited to) the following; COSHH regulations, Gas Safety (Installation and Use) Regulations 1998, Health and Safety Document No. 635 (The Electricity at Work Regulations 1989), BS7671 (IEE Wiring Regulations) and the Water Supply (Water Fitting) Regulations 1999, or The Water Bylaws 2000 (Scotland). It should also be in accordance with the relevant requirements of the Local Authority, Building Regulations, The Building Regulations (Scotland), The Building Regulations (Northern Ireland) and the relevant recommendations of the following British Standards:

BS 6700: Services supplying water for domestic use within buildings and their curtilages.

BS 6798: Specification for installation of gas fired boilers not exceeding 60 kW input.

BS 6891: Specification for installation of low pressure gas pipework up to 28 mm (R1) in domestic premises (2nd family gas).

BS 7593: Treatment of water in domestic hot water central heating systems. Institute of Gas Engineers Publication IGE/UP/7/1998: "Guide for gas installations in timber framed housing"

BS. 5482 Pt. 1 Domestic butane and propane gas burning installations.

IGE/UP1 Soundness testing and purging of industrial and commercial gas installation.

IGE/UP2 Gas installation pipework, boosters and compressors on industrial and commercial premises.

IGE/UP10 Installation of gas appliances in industrial and commercial premises.

BS. 6644 Installation of gas fired hot water boilers of rated inputs between 60 kW and 2 MW (2nd and 3rd family gases).

BS. 5449 Forced circulation hot water central heating systems for domestic premises. Note: only up to 45 kW.

BS. 6880 Low temperature hot water heating systems of output greater than 45 kW.

Part 1 Fundamental and design considerations.

Part 2 Selection of equipment.

Part 3 Installation, commissioning and maintenance.

BS. 4814 Specification for: Expansion vessels using an internal diaphragm, for sealed hot water heating systems.

BS. 5440 Installation and maintenance of flues and ventilation for gas appliances of rated input not exceeding 70 kW net (1st, 2nd and 3rd family gases).

Part 1 Specification for installation of flues.

Part 2 Specification for installation and maintenance of ventilation for gas appliances.

3 Description of the unit

3 Description of the unit

3.1 Description of the cylinder

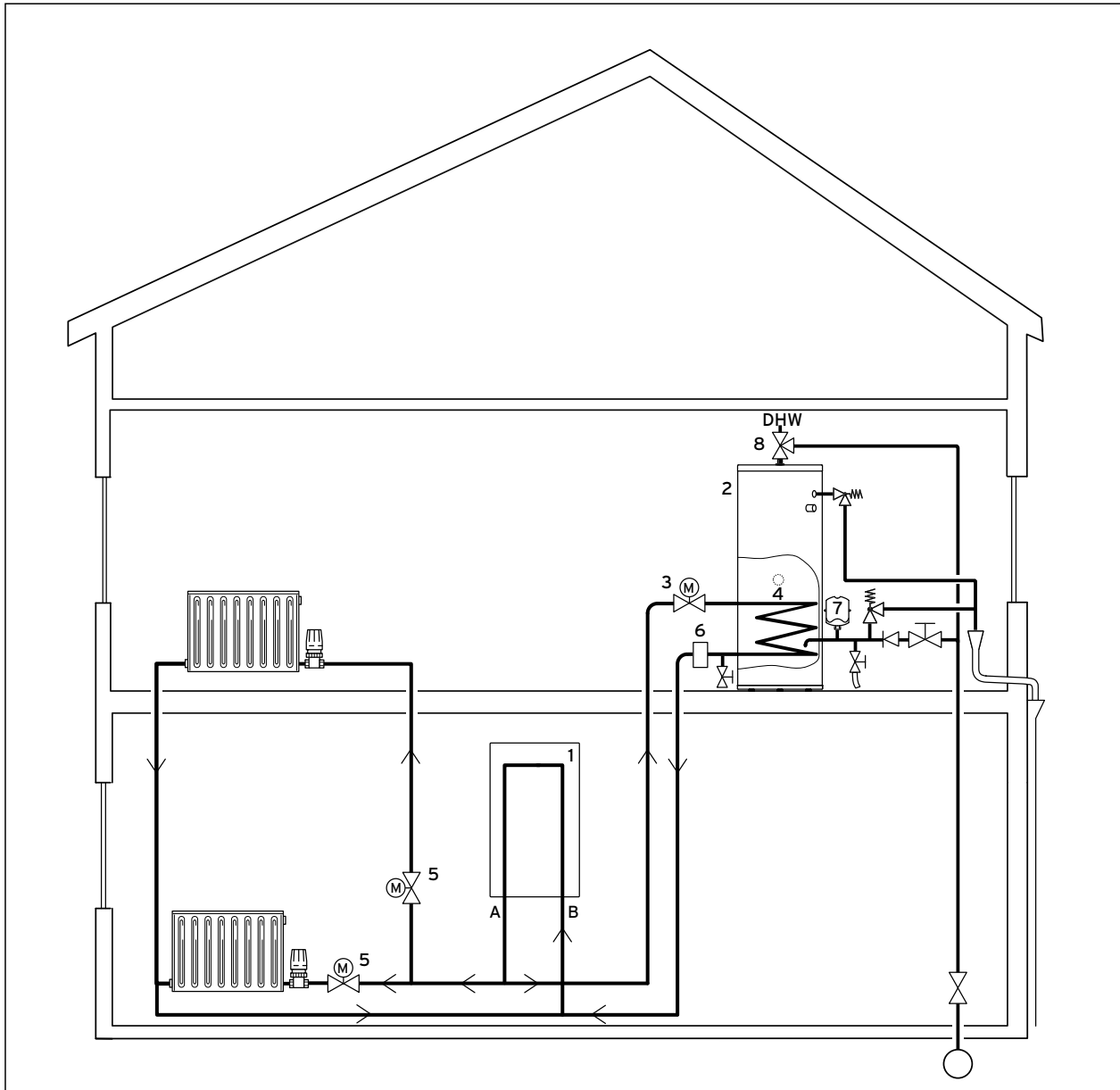

Fig. 3.1 Hydraulics diagram for the connection of the unvented domestic hot water cylinder

Key

- 1 Gas-fired wall-hung boiler
- 2 Cylinder
- 3 Two port motorised valve (230 V, supplied with cylinder)
- 4 Electric immersion heater
- 5 Two port motorised valve (230 V)

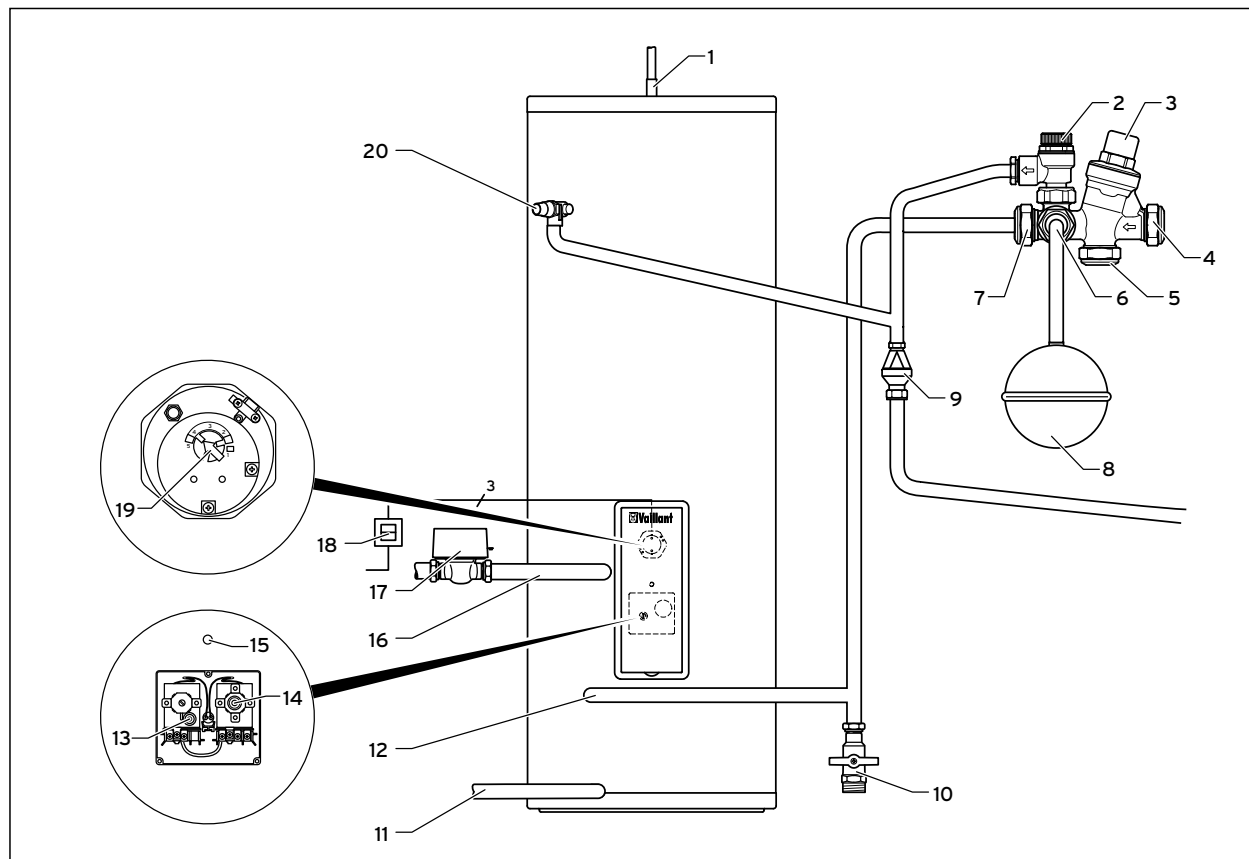

Fig. 3.2 Functional elements of uniSTOR domestic hot water cylinder

Key

- 1 Hot water draw off
- 2 Expansion relief valve (one-way valve, 6.0 bar)
- 3 Pressure reducing valve (3.5 bar) with line strainer
- 4 Cold water connection
- 5 Balanced pressure cold water inlet
- 6 Connection for hot water expansion vessel
- 7 Cylinder connection
- 8 Hot water expansion vessel
- 9 Tundish
- 10 Cylinder drain valve
- 11 Primary heater return
- 12 Cold water inlet
- 13 Primary heating circuit thermal cut-out, set to 80°C, to be connected to the two port motorised valve in order to isolate the primary heat source if a fault occurs.
- 14 Cylinder thermostat (25°C to 65°C)
- 15 Primary heating circuit immersion sleeve (NTC)
- 16 Primary heater flow
- 17 Two port motorised valve
- 18 Double pole isolating switch for electric immersion heater
- 19 Electric immersion heater with thermostat and thermal cut-out
- 20 Temperature and pressure relief valve (90°C, 7 bar)

3 Description of the unit

The uniSTOR domestic hot water cylinder is available in six sizes: 120, 155, 180, 210, 260, and 310 litres. The cylinder is made from stainless steel and is insulated with EPS with heat radiation absorbers. The cylinder is supplied along with all required cold and hot water control devices and a two port motorised valve.

The cylinder works with the pressure of the water supply line and does not need a cold water tank for its supply. The cylinder has hot and cold water inlets with a diameter of 22 mm. To enable the cylinder to work as well as possible, a cold water supply with a dynamic pressure and flow rate that are appropriate for the system is required (→ **section 5.3.1**).

Typical applications:

- Property with a single bathroom: uniSTOR 120 litres
- Property with a single bathroom and additional shower: uniSTOR 120 or 155 litres
- Property with two bathrooms: uniSTOR 155 or 180 litres
- Property with two bathrooms and additional shower: uniSTOR 180 or 210 litres
- Larger properties: uniSTOR 260 or 310 litres

3.1.1 Safety devices

The cylinder is delivered with all safety and control devices for the operation of the unvented domestic hot water supply system:

- Temperature and pressure relief valve (90 °C, 7 bar)
- Pressure reducing valve (3.5 bar) with line strainer
- Expansion relief valve (one-way valve, 6.0 bar)
- Thermal cut-out for electric immersion heater
- Primary heating circuit thermal cut-out, set to 80 °C, to be connected to the two port motorised valve in order to isolate the primary heat source if a cylinder thermostat fault occurs.

3.1.2 Cylinder operating elements

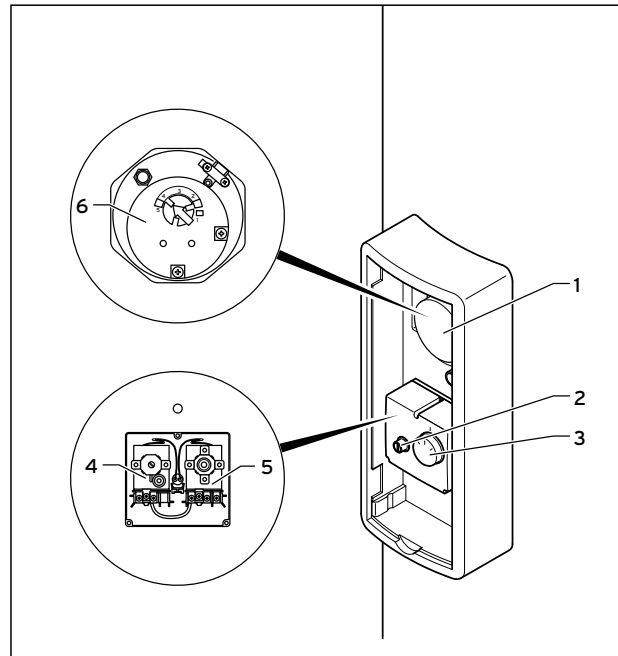

Fig. 3.3 Cylinder operating elements

Key

- 1 Electric immersion heater cover
- 2 Cover cap for reset button for reheating circuit TCO
- 3 Primary heating circuit temperature controller
- 4 Primary heating circuit thermal cut-out
- 5 Cylinder thermostat
- 6 Electric immersion heater

The following are premounted at the factory for the unvented uniSTOR domestic hot water cylinder:

- Cylinder thermostat (**5**) and reheating circuit thermal cut-out (**4**)
- Electric immersion heater (**6**) with thermal cut-out and cylinder thermostat

The cylinder must be properly wired in order to comply with G3 building regulations.

3.1.3 Electric immersion heater

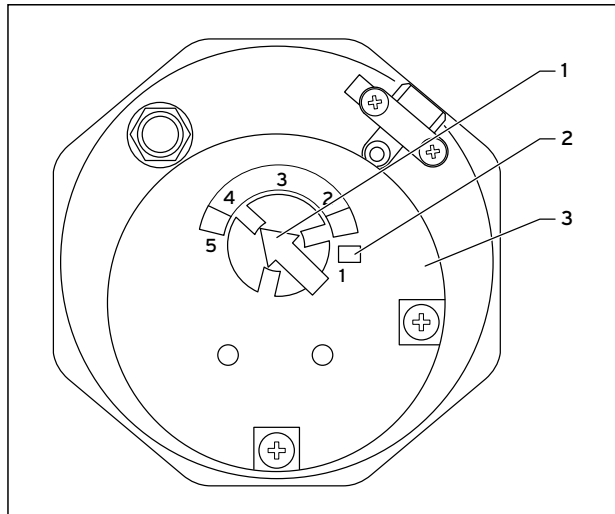

Fig. 3.4 Electric immersion heater operating elements

Key

- 1 Electric immersion heater temperature controller
- 2 Electric immersion heater TCO reset button
- 3 Electric immersion heater

The cylinder is equipped with an additional electric immersion heater (**3**) with a heating output of 3 kW. The electric immersion heater is located behind the top front cladding. The electric immersion heater is designed for use in unvented cylinders and has a thermostat with a temperature controller (**1**) and a thermal cut-out (TCO) with a reset button (**2**).



If you need to make a replacement, you must use the correct electric immersion heater with a thermal cut-out for overheating protection. The seal of the electric immersion heater must also always be replaced. Use only original replacement parts from Vaillant Ltd.



Inspection access to the cylinder is available through the immersion heater boss.

Setting the hot water temperature

You can set the hot water temperature by pointing the arrow on the temperature controller (**1**) of the electric immersion heater to a number between 1 and 5. The following table contains the approximate hot water temperature for each of the five settings.

Setting	Hot water temperature
1	20 °C
2	35 °C
3	45 °C
4	60 °C
5	68 °C

Table 3.1 Setting the hot water temperature

3.1.4 Hot water temperature regulation

You can control the hot water temperature using a Vaillant dual-channel eBUS controller or a separate hot water controller.



Danger!
Risk of burns and scalds!

Water at a temperature of more than 60 °C can escape from the water draw-off point.

- ▶ Install a hot water thermostat mixer in the hot water pipe to provide effective scald protection.
- ▶ Set the hot water thermostat mixer to less than 60 °C and check the temperature at a hot water draw-off point.

3.1.5 Wiring

If you are using an eBUS-compatible Vaillant gas-fired wall-hung boiler, you can use the Vaillant Control Center VR 65 or the Vaillant VR 61 mixer module for the system cabling.

If you are using a non-eBUS-compatible Vaillant gas-fired wall-hung boiler or a third-party boiler, you can use a standard cabling box.

3.1.6 Combination of uniSTOR domestic hot water cylinder and controllers

The following controllers can be used to regulate hot water production:

- Vaillant dual-channel eBUS controller, VR 65, VR 61, or a timer (from a third-party manufacturer).
- If you are using an eBUS-compatible Vaillant gas-fired wall-hung boiler, you can control the heating using a programmable Vaillant VRT room thermostat or a VRC weather compensator.
- If you are using a non-eBUS-compatible Vaillant gas-fired wall-hung boiler or a third-party boiler, you can use a Vaillant VRT 30 room thermostat or one of the room thermostats commonly available on the market.

3 Description of the unit

3.2 Technical data

	Unit	VIH GB 120/2 S	VIH GB 155/2 S	VIH GB 180/2 S	VIH GB 210/2 S	VIH GB 260/2 S	VIH GB 310/2 S
Total capacity	litres	120	155	180	210	260	310
Actual capacity	litres	119,2	149,1	176,6	211,2	250,3	298,5
Hot water capacity	litres	104,0	136,7	166,4	203,9	247,5	270,5
Maximum supply pressure to pressure reducing valve	MPa (bar)	1,2 (12)					
Rated pressure of cylinder	MPa (bar)	0,7 (7)					
Maximum operating pressure of heating coil	MPa (bar)	0,35 (3,5)					
Operating pressure	MPa (bar)	0,35 (3,5)					
Pressure reducing valve	MPa (bar)	0,35 (3,5)					
Expansion relief valve	MPa (bar)	0,6 (6)					
Temperature and pressure relief valve	°C, MPa (bar)	90, 0,7 (7)					
Charge pressure of hot water expansion vessel	MPa (bar)	0,4 (4)					
Maximum temperature of heating circuit	°C	85					
Maximum temperature of potable hot water	°C	85					
Standing heat loss	kW/24 h	1,26	1,53	1,66	1,89	2,07	2,26
Heat up time according to EN 12897	mins	18	23	24	28	35	42
Recovery time (70% capacity)	mins	16	18	17	20	25	30
Primary heat exchanger performance	kW	18,6	18,8	22,0	22,6	22,3	20,4
Flow rate for primary heat exchanger performance	l/min	23,3					
Primary heat exchanger pressure drop	mbar	97	97	116	116	116	115
Primary heat exchanger volume	litres	2,94	2,94	3,56	3,56	3,56	3,56
Primary heat exchanger surface area	m ²	0,62	0,62	0,75	0,75	0,75	0,75
Dimensions							
Height	mm	1001	1191	1371	1593	1843	2153
Height with hot water draw off	mm	1033	1223	1403	1625	1875	2185
Topple measure	mm	1138	1308	1473	1680	1918	2217
Diameter	mm	554,5					
Depth	mm	633					
Net weight	kg	26	29	32	36	41	46
Weight (full)	kg	145	177,8	209	248	291	345
Connections							
Cold water inlet		22 mm unprofiled pipe (crimp joints)					
Hot water draw off		22 mm unprofiled pipe (crimp joints)					
Pressure-controlled cold water inlet		22 mm unprofiled pipe (crimp joints)					
Secondary return		15 mm unprofiled pipe (crimp joints)					
Primary heater flow		22 mm unprofiled pipe (crimp joints)					
Primary heater return		22 mm unprofiled pipe (crimp joints)					
Primary heating circuit immersion sleeve size	mm	8					
Electrical connections							
Immersion heater (according to ENBS 60335)		2.7 kW, 230 V, 50 Hz					
Length of immersion heater	inch	14					
Two port motorised valve		230/240 V, 50 Hz					
Cylinder thermostat		230/240 V, 50 Hz					
Material data							
Cylinder body material		Stainless steel (1.4521)					
Cylinder jacket material		Polypropylene					
Insulation material		EPS with heat radiation absorber					
Insulation thickness	mm	50					
Corrosion protection		Stainless steel					
Blowing agent for insulation material		Pentane (GWP < 5)					
ODP		0					

Tab. 3.1 Technical data for uniSTOR domestic hot water cylinder



The heat up time is based on a flow rate of 1400 l/h at 80 °C.
Temperature rise from 15 °C to 60 °C.

Dimensions

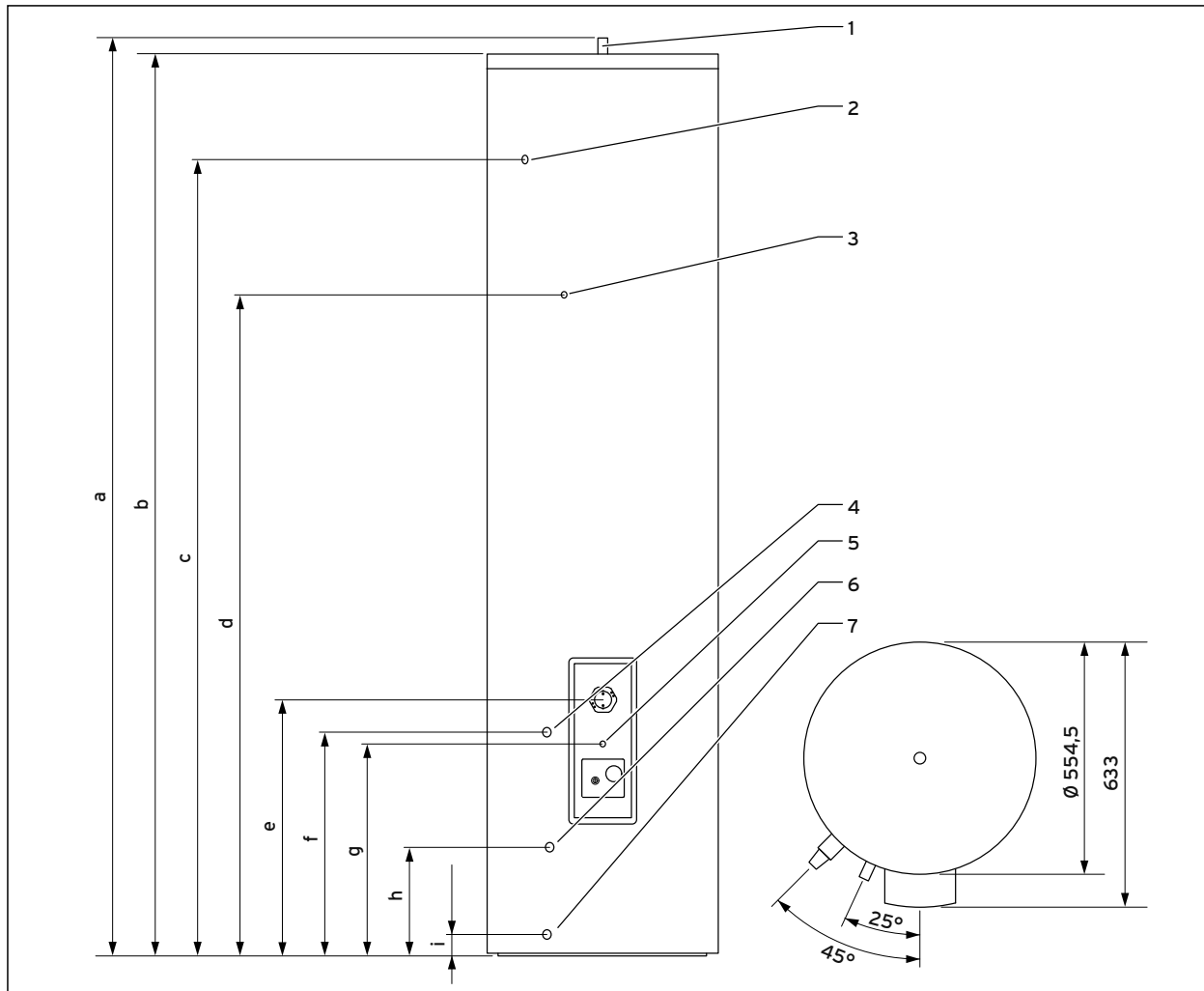

Fig. 3.5 Dimensions of uniSTOR domestic hot water cylinder

Key

- 1 Hot water draw off
- 2 Temperature and pressure relief valve connection
- 3 Secondary return
- 4 Primary heater flow
- 5 Primary heating circuit immersion sleeve
- 6 Cold mains inlet connection
- 7 Primary heater return

Unit type	a	b	c	d	e	f	g	h	i
VIH GB 120/2 S	1033	1001	749	714	616	534	506	259	51
VIH GB 155/2 S	1223	1191	939	857	616	534	506	259	51
VIH GB 180/2 S	1403	1371	1119	992	616	534	506	259	51
VIH GB 210/2 S	1625	1593	1341	1158	616	534	506	259	51
VIH GB 260/2 S	1875	1843	1591	1346	616	534	506	259	51
VIH GB 310/2 S	2185	2153	1901	1578	616	534	506	259	51

Tab. 3.3 Dimensions

4 Installation

4 Assembly

4.1 Scope of delivery

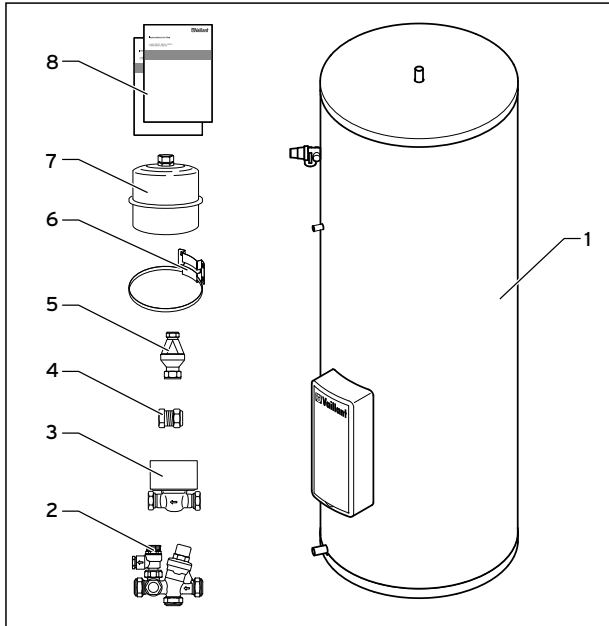

Fig. 4.1 Scope of delivery

Item	Quantity	Component
1	1	Domestic hot water cylinder with insulation in separate packaging
2	1	Safety assembly (pressure reducing valve, expansion relief valve, connections for pressure-controlled cold water inlet and hot water expansion vessel)
3	1	Two port motorised valve
4	1	Plug for secondary return
5	1	Tundish
6	1	Assembly set for hot water expansion vessel
7	1	Hot water expansion vessel: 12 l for VIH GB 120/2 S and VIH GB 155/2 S 18 l for VIH GB 180/2 S and VIH GB 210/2 S 25 l for VIH GB 260/2 S and VIH GB 310/2 S
8	2	Installation and maintenance instructions and operating instructions (packaged with the cylinder)

Table 4.1 Scope of delivery

- Check the scope of delivery for completeness.
- Make sure the cylinder is stored in an upright position in a dry environment prior to its installation.

4.2 Transporting the cylinder



Danger!

Risk of injury due to heavy load!

Heavy load can cause injuries.

- At least two people should lift the cylinder to prevent injuries.
- Use a suitable transportation aid (sack truck or similar).

- Transport the packaged cylinder to the installation site.
- Only remove the cylinder from its packaging once it reaches the installation site.

4.3 Installation site

Position the domestic hot water cylinder as near as possible to the heater to prevent unnecessary heat loss.

Place the cylinder in a suitable location in the building, paying attention to the following:

- The tundish discharge pipe must be installed with a minimum downward slope of 1:200 and must end in a safe and visible place.
- The installation surface must be flat and capable of bearing the weight of the full cylinder.
- The installation site must not be at risk of frost. If necessary, install a frost protection thermostat.
- The control system for the installed cylinder thermostat beneath the front plate must be easily accessible to the operator.
- There must be sufficient space for mounting, maintaining and replacing the electric immersion heater.
- The floor must be even.
- There must be sufficient space for installing, maintaining and replacing the expansion vessel.
- Choose a cylinder installation site that allows the potable water and heating lines to be laid in an appropriate manner.
- To prevent energy losses in accordance with current building regulations, provide all system pipes with thermal insulation.

5 Installation



Danger! **Risk of injuries and damage due to improper installation!**

Improper installation can impede the operational safety of the unit.

- Only a competent person may install and commission the unit.
This person takes responsibility for making sure that the unit is installed and commissioned for the first time correctly and in accordance with regulations.



Danger! **Risk of burns from lines!**

There is a risk of burns from system pipes without thermal insulation. Energy losses also occur in such cases.

- Provide all system pipes with thermal insulation.
- Use screw connections to close all supply lines.



Caution! **Risk of damage resulting from improper use and/or unsuitable tools!**

Improper use and/or unsuitable tools may result in material damage (e.g. gas or water leaks).

- Always use a suitable open-ended spanner to tighten or undo threaded connections.
- Do not use pipe wrenches, extensions, etc.



Caution! **Risk of damage from leaks!**

Mechanical stress on supply lines can result in leaks and thus damage to the heat pump.

- Avoid mechanical stress on supply lines!

5.1 Installing pipes for the reheating circuit

- Make sure that the pipes in the reheating circuit between the gas-fired wall-hung boiler and cylinder are as short as possible. Use copper piping with a minimum diameter of 22 mm.

A heating pump is installed in all Vaillant gas-fired wall-hung boilers (apart from the ecoTEC plus 400 with open ventilation). If you are using the cylinder with another gas-fired wall-hung boiler as per GB standards, you may have to install a suitable heating pump in the reheating circuit.

Installing the two port motorised valve

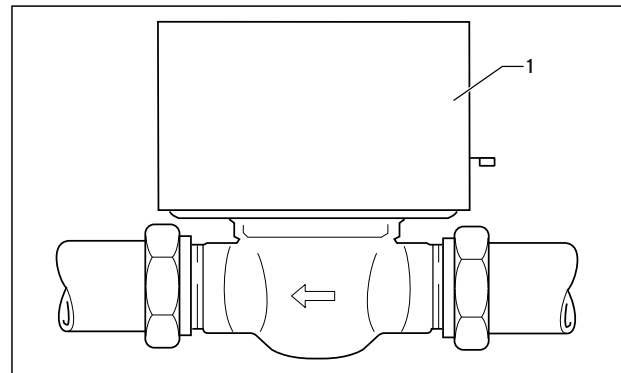

Fig. 5.1 Two port motorised valve

The two port motorised valve prevents the cylinder from overheating.

- Install the two port motorised valve (1) supplied with the cylinder in the flow line (A → fig. 3.1) of the gas-fired wall-hung boiler.
- Note the direction of flow, which is marked with arrows.



The two port valve must only be installed horizontally and with the valve head facing upwards (→ fig. 5.1).

5 Installation

5.2 Installing hot water pipes

- Connect the hot water piping to the 22 mm hot water draw off of the cylinder.
- Lay the 22 mm piping up to the first T-piece. The required diameter of subsequent pipes depends on the system design.

Installing the circulation line

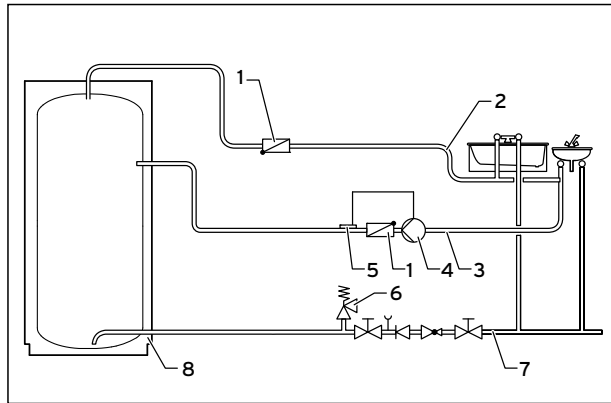

Fig. 5.2 Installing the circulation line

Key

- 1 Non-return valve
- 2 Hot water pipe
- 3 Circulation line
- 4 Circulation pump
- 5 Contact thermostat
- 6 Expansion relief valve
- 7 Cold mains inlet
- 8 Domestic hot water cylinder

Where possible, avoid installing a circulation line, since a circulation line results in higher energy consumption.



If you are not using the secondary return, this must be properly closed off with the cap included in delivery.



If you are installing a circulation line, an additional expansion vessel may be required in certain circumstances.

If the installation of a circulation line is required, keep circulation operations to a minimum by only using circulation mode when required for demand and temperature reasons.

The cylinder has a connection with a 15 mm diameter for a second circulation line.

- Connect a WRAS-approved circulation pump (4) with a non-return valve to the secondary return.
- Connect the circulation line (3) to the hot water pipe (2).

5.3 Installation of cold mains inlet

5.3.1 Pressure in cold mains inlet

The efficiency of an unvented cylinder depends on the available pressure in the cold mains inlet and the flow rate. To obtain optimum cylinder output, there must be a suitable cold mains inlet, i.e. the measured static line pressure must be at least 2.0 bar. A corresponding flow rate of at least 20-25 l/min must be available.



The pressure in the cold mains inlet will be reduced at times of high consumption. Thus, measurements should be taken at such times.

The cylinder still works satisfactorily with a pressure below 2 bar but the flow rate is reduced. If the pressure is below 1 bar, you should not install an unvented cylinder. Vaillant Ltd. can provide information on alternative hot water supply systems.

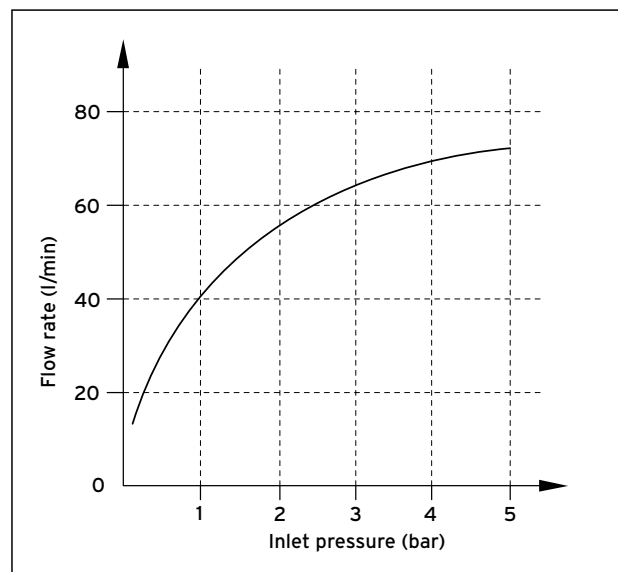

Fig. 5.3 Maximum flow rate of the cold water assembly based on the supply pressure

The displayed flow rates apply to installations in which the cold water supply has a dynamic pressure and flow rate appropriate for the system.

If the static water pressure is less than 1 bar, contact Vaillant Ltd.

5.3.2 Mounting the safety assembly



Caution!
Risk of damage to the cylinder as a result of excess pressure!

Excess pressure can cause the cylinder to burst.

- Make sure that there is no stop valve installed between the safety assembly and the cylinder.

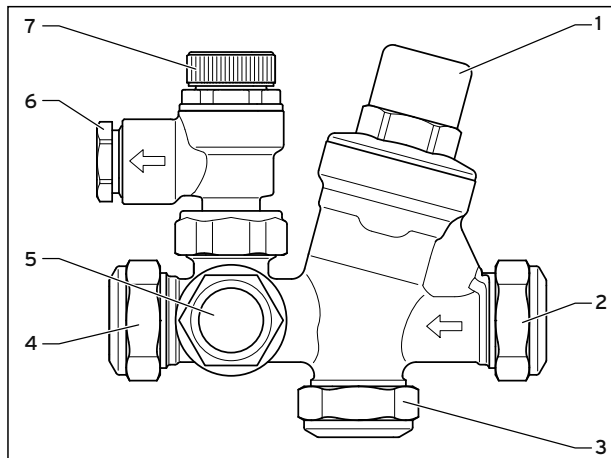

Fig. 5.4 Safety assembly

Key

- 1 Pressure reducing valve with line strainer
- 2 Cold water inlet
- 3 Pressure-controlled cold water inlet
- 4 Cylinder connection
- 5 Hot water expansion vessel connection
- 6 15 mm expansion relief valve connection
- 7 Expansion relief valve

- During the installation process, position the valves so that you are able to connect the 15 mm connection (6) of the expansion relief valve (7) with the tundish. Note the direction of flow, which is marked on the safety assembly with arrows.



The safety assembly must be installed horizontally with the expansion relief valve facing upwards (→ fig. 5.4) in order to prevent the build-up of dirt.



Caution!
Risk of damage to the cylinder as a result of excess pressure!

Excess pressure can cause the cylinder to burst.

- Make sure that the expansion relief valve outlet is not covered or closed.

- Mount the discharge pipe of the expansion relief valve with a constant slope to the outside. The discharge pipe must finish at a safe and visible point where there is no danger of it freezing up and where it poses no risk of injury to persons.
- Actuate the expansion relief valve regularly to prevent calcification.
- Connect the cylinder to the cylinder connection (4).
- For the pipe from the main stop valve of the building to the cylinder, use copper piping with a diameter of at least 22 mm to ensure that the cylinder is as efficient as possible. This is particularly important for installations with a balanced cold water inlet (3).
- Mount the safety assembly in the cold mains inlet on the cylinder.
- If necessary, establish the connection to the cold water inlet (3) with pressure compensation of the safety assembly.
- Depending on the fittings used and the type of the draw-off points, it may be necessary to install a backflow preventer in the pressure-controlled cold water inlet.



If you mount the safety assembly above the cylinder, you do not need to drain the cylinder in order to maintain the safety assembly. Make sure there is sufficient space for maintenance and connection of the discharge pipe of the expansion relief valve.

When the discharge pipes are connected, the expansion relief valve may not be more than 600 mm away from the temperature and pressure relief valve (→ fig. 5.5).

5.3.3 Mounting the expansion vessel

The Vaillant domestic hot water cylinder is delivered with an external expansion vessel.

Connect this expansion vessel to the installed safety assembly as follows:

- Screw the expansion vessel directly to the safety assembly via the provided connection (5) or
- Connect the expansion vessel with the safety assembly via a copper pipe or suitable hose line. Make sure the expansion vessel is supported sufficiently.
- Use the supplied wall bracket if you want to mount the expansion vessel to a wall.



In regions with high water pressure (4 bar or more), you can also connect the mixer tap for a bath or shower to the cold water inlet with pressure compensation (3) of the safety assembly. This ensures that the hot and cold water supply to the mixer tap have the same pressure. You should install the cold water supply for all other connections using a T-piece before the safety assembly in the cold mains inlet to the cylinder.

5 Installation

5.3.4 Mounting the drain valve

- Mount a drain valve (10) (→ fig. 3.2) as low as possible between the cylinder and the safety assembly in the cold mains inlet.

The drain valve must be provided by the customer. We recommend mounting a hose which reaches about 1 m under the base of the cylinder to the outlet of the drain valve.

5.3.5 Laying the pipes to the tundish

- Connect the temperature and pressure relief valve and the expansion relief valve to the tundish using 15 mm piping.
- Lay the tundish discharge pipe (→ section 5.4).



The tundish discharge pipes must be laid at a sufficient distance from electrical components in accordance with valid building regulations.

5.4 Installation of discharge pipe

5.4.1 Design of discharge pipe



Danger! **Risk of burns and scalds resulting from escaping hot water!**

In the event of a fault, hot water can escape suddenly from the discharge pipe of the expansion relief valve.

- Lay the discharge pipe so that it ends at an easily visible point inside or outside the building where escaping hot water does not pose a risk to persons.

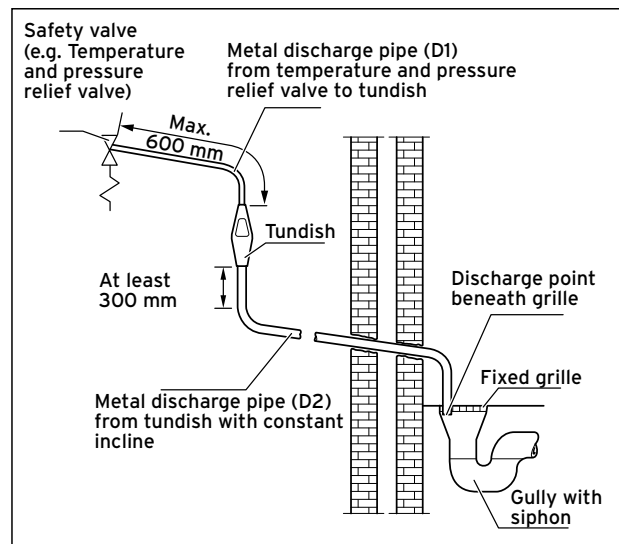

Fig. 5.5 Typical drainage installation

The discharge connections of the temperature and pressure relief valve and the expansion relief valve must be connected to the supplied tundish via 15 mm copper piping. The tundish should be mounted vertically, as close to the cylinder as possible and not more than 600 mm from the connection of the temperature and pressure relief valve. It must be mounted in the same room as the cylinder at a sufficient distance from the electrical components. The discharge pipes from the temperature and pressure relief valve and the expansion relief valve can be joined above the tundish using a T-piece. The discharge pipe from the 22 mm connection of the tundish must be laid using copper piping with a diameter of at least 22 mm to a safe and visible discharge point. There must be a vertical section of pipe at least 300 mm long beneath the tundish before any bends or elbows in the pipework. If the total resistance of the discharge pipe exceeds the values specified in Tab. 5.1 below, you must increase the diameter of the piping. When installing the discharge piping, you must observe Directive G3 (→ section 2.2).

Minimum diameter of discharge pipe (D2) from tundish	Maximum permissible total resistance, expressed as straight pipe length (without elbows or bends)	Resistance due to each elbow or bend
22 mm	up to 9 m	0.8 m
28 mm	up to 18 m	1.0 m
35 mm	up to 27 m	1.4 m

Tab. 5.1 Sizing of copper discharge pipe "D2" for G1/2 temperature and pressure relief valve outlet size

Worked example

The example below is for a G1/2 temperature relief valve with a discharge pipe (D2) having 4 No. 22 mm elbows and length of 7 m from the tundish to the point of discharge.

From Table 5.1:

Maximum resistance allowed for a straight length of 22 mm copper discharge pipe (D2) from a G1/2 temperature relief valve is: 9.0 m.

Subtract the resistance for 4 No. 22 mm elbows at 0.8 m each = 3.2 m

Therefore the maximum permitted length equates to: 5.8 m, which is less than the actual length of 7 m therefore calculate the next largest size.

Maximum resistance allowed for a straight length of 28 mm pipe (D2) from a G1/2 temperature relief valve is: 18 m.

Subtract the resistance of 4 No. 28 mm elbows at 1.0 m each = 4.0 m.

Therefore the maximum permitted length equates to: 14 m.

As the actual length is 7 m, a 28 mm (D2) copper pipe will be satisfactory.

A suitable place for the end of the discharge pipe is, for example, beneath a fixed grille above the odour seal in a gully with a siphon. Low discharge pipes, for example up to 100 mm above external surfaces such as car and other parking spaces, grasslands, etc. can be used provided that they are secured by a wire fence or something similar to prevent children from coming into contact with the waste water and provided that the system is not visible. You must not install any valves or stop cocks in the discharge pipe.

- Make sure that the discharge pipe from the tundish to the drain has a constant downward incline of at least 1:200.

The discharge pipe from the pressure relief valve of the Vaillant gas-fired wall-hung boiler can be connected to the horizontal discharge pipe of the cylinder behind the tundish using a T-piece.

5.4.2 High drain

Fig. 5.6 High drain connection

The method illustrated in fig. 5.6 is allowed provided that no-one inside or outside the building is endangered by the discharge point.

Examples of points to consider when deciding whether a location is suitable for the high drain:

- The possibility (taking into account the effect of the wind) that a person might be located in the area where the water escapes, and, if this is the case, whether the water is sufficiently cooled by that point to pose no danger. Thermal conductivity of the structure's surface, climatic conditions and location and orientation of the discharge pipe may or may not have an effect on reducing the temperature of the discharge water.
- The position of windows and other openings.
- The probability of prams being parked under the drain.
- The resistance of the surface to hot water.
- The possibility of ice forming if the water is discharged onto paths.

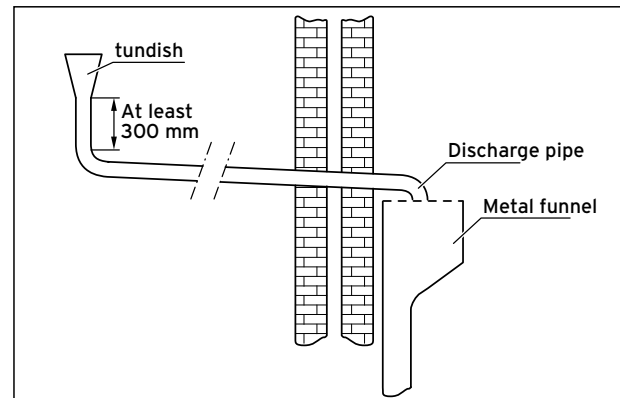
5 Installation

5.5 Electrical installation



Danger!

Risk of death from electric shock!

Improperly executed electrical connections can impair the operational safety of the unit.

- The electrical installation may only be performed by a competent person approved at the time by the Health and Safety Executive.



Danger!

Risk of death from electric shock!

If the appliance is not earthed, life-threatening voltage can reach the piping and water draw-off points.

- The appliance must be earthed.

Wiring should be installed by a qualified, competent person in accordance with the building regulations, Part P of the current IEE regulations, and all other applicable regulations and directives.

You can use standard commercial cables for the wiring:

- Minimum cross-section of conductors: 1.5 mm²
- Maximum length of bus cables: 300m

230 V supply lines and bus cables must be laid separately above lengths of 10 m.



The discharge pipes of the tundish, drain valves and motorised valves, etc. must be laid at a distance from electrical components.

5.5.1 Electrical connection of control components

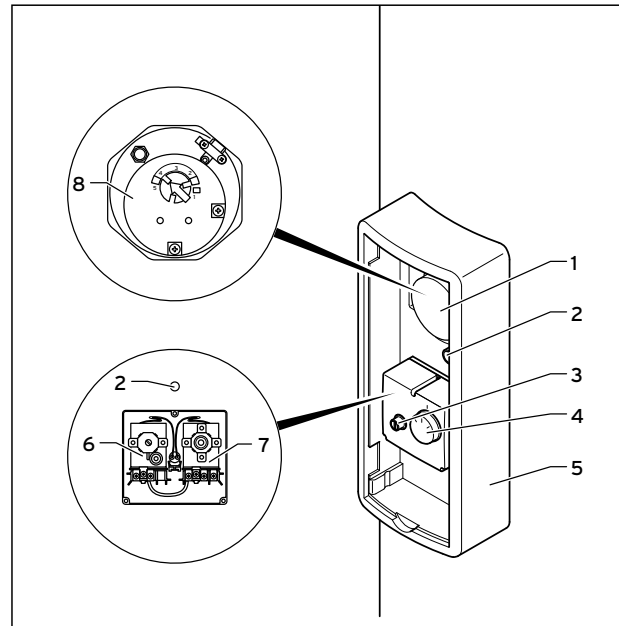

Fig. 5.7 Cylinder temperature control

Key

- 1 Electric immersion heater cover
- 2 Primary heating circuit immersion sleeve (NTC)
- 3 Cover cap for reset button for reheating circuit TCO
- 4 Primary heating circuit temperature controller
- 5 Casing
- 6 Primary heating circuit thermal cut-out
- 7 Cylinder thermostat
- 8 Electric immersion heater

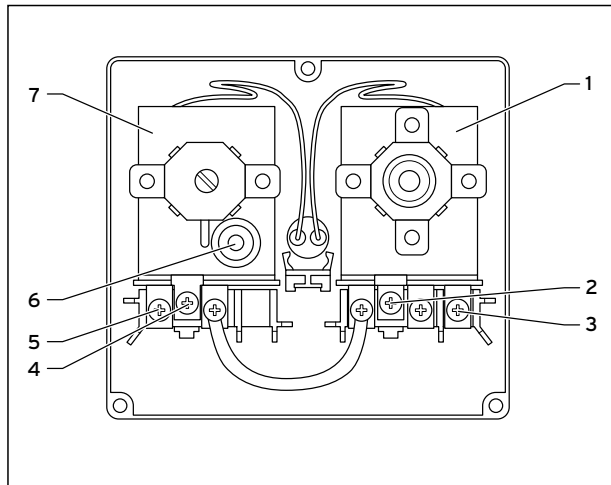

Fig. 5.8 Cylinder thermostat and thermal cut-out (TCO) for reheating circuit

Key

- 1 Cylinder thermostat
- 2 Cylinder thermostat protective earth terminal
- 3 Cylinder thermostat terminal 1
- 4 Primary heating circuit TCO protective earth terminal
- 5 Primary heating circuit TCO C terminal
- 6 Primary heating circuit TCO reset button
- 7 Primary heating circuit thermal cut-out (TCO)



Before wiring the control components, dismantle the casing (5) (→ fig. 5.7) to facilitate work on the components. When reinstalling the casing, use the cutouts in the casings for routing the cables.

5.5.2 Connecting up the electric immersion heater

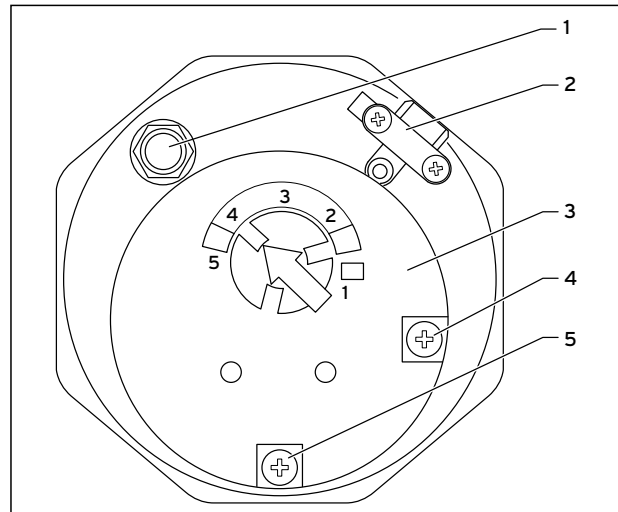

Fig. 5.9 Electrical connection of electric immersion heater

Key

- 1 Protective earth terminal (PE)
- 2 Cable grip
- 3 Electric immersion heater
- 4 Neutral conductor terminal (N)
- 5 Outer conductor terminal (L)



Danger!

Risk of death from electric shock!

Without potential equalisation, life-threatening voltage can reach the piping and water draw-off points.

- Earth the electric immersion heater.



Caution!

Corrosion and short circuits can occur due to incorrect earthing!

If you insert an immersion heater into the cylinder, the external voltage may build up electrical potential in the water which can result in the electrochemical corrosion of the immersion heater.

- Make sure that both the hot water and cold mains inlets are connected to the earth line by means of an earth cable directly on the cylinder.
- You must also make sure that the immersion heater is connected to the earth line via the earthing terminal.

5 Installation

- Remove the top front cladding from the cylinder.
- Dismantle the electric immersion heater cover.
- Install a separate electrical power supply for the electric immersion heater in accordance with current IEE regulations (BS 7671).
 - Use heat-resistant cables (1.5 mm², 3-wire HOFR-coated) as per BS 6141 for the cabling of the electric immersion heater.
 - Use the cable grip (2) to firmly secure the supply cable of the immersion heater.
 - Connect the electric immersion heater to the power mains via a double pole isolating switch with a contact separation of at least 3 mm in both poles.
 - Protect the circuit using a 16 A fuse.
- Mount the cover for the electric immersion heater.



Only switch the immersion heater on once the cylinder is completely full.

With the isolating switch, the electric immersion heater can be switched on if the reheating device has malfunctioned.

5.5.3 Options for combining control components

- For the installation, use the connection wiring diagram specified in Tab. 5.2 for the gas-fired wall-hung boiler and control components used.

Gas-fired wall-hung boiler used

eBUS-compatible gas-fired wall-hung boiler such as the Vaillant ecoTEC or non-eBUS-compatible gas-fired wall-hung boiler from Vaillant or a third-party manufacturer.

Wiring

Wiring via the Vaillant VR 61 mixer module or Control Center VR 65 as a system solution which enables Vaillant dual-channel eBUS controllers (low-voltage) to be used with valves and domestic hot water cylinders in the traditional 230 V range in the English market. Alternatively, using a standard cabling box.

Control system of the heating circuits

The heating circuits can be controlled via Vaillant programmable room thermostats or weather compensators in conjunction with the Vaillant range of eBUS-compatible gas-fired wall-hung boilers. You can also use tested standard operating elements (see above).

For an overview of the combination options for these control components, see Tab. 5.2.



All wiring must be carried out in accordance with BS 7671: "Requirements for electrical installations" (IEE wiring regulations, current edition).

Regulation of cylinder reheating

The regulation of the reheating of the cylinder takes place via a Vaillant dual-channel eBUS controller or a timer (third-party manufacturer).

Gas-fired wall-hung boiler	Wiring via	Control system of the heating circuits	Regulation of cylinder reheating	Hydraulic plan	Connection wiring diagram
Vaillant ecoTEC, eBUS-compatible	VR 65	Vaillant dual-channel eBUS controller	Vaillant dual-channel eBUS controller with VR 65	S plan	1 → fig. 5.10
Vaillant ecoTEC, eBUS-compatible	VR 65	Vaillant dual-channel eBUS controller	Vaillant dual-channel eBUS controller with VR 65	Y plan	2 → fig. 5.11
Non-eBUS-compatible boiler from a third-party manufacturer	Standard cabling box	Programmable timer and room thermostat	Timer	S or Y plan	6 → fig. 5.12

Tab. 5.2 Options for combining control components

5 Installation

5.5.4 Installing the control components in accordance with the connection wiring diagrams

Connection wiring diagram 1 (S plan)

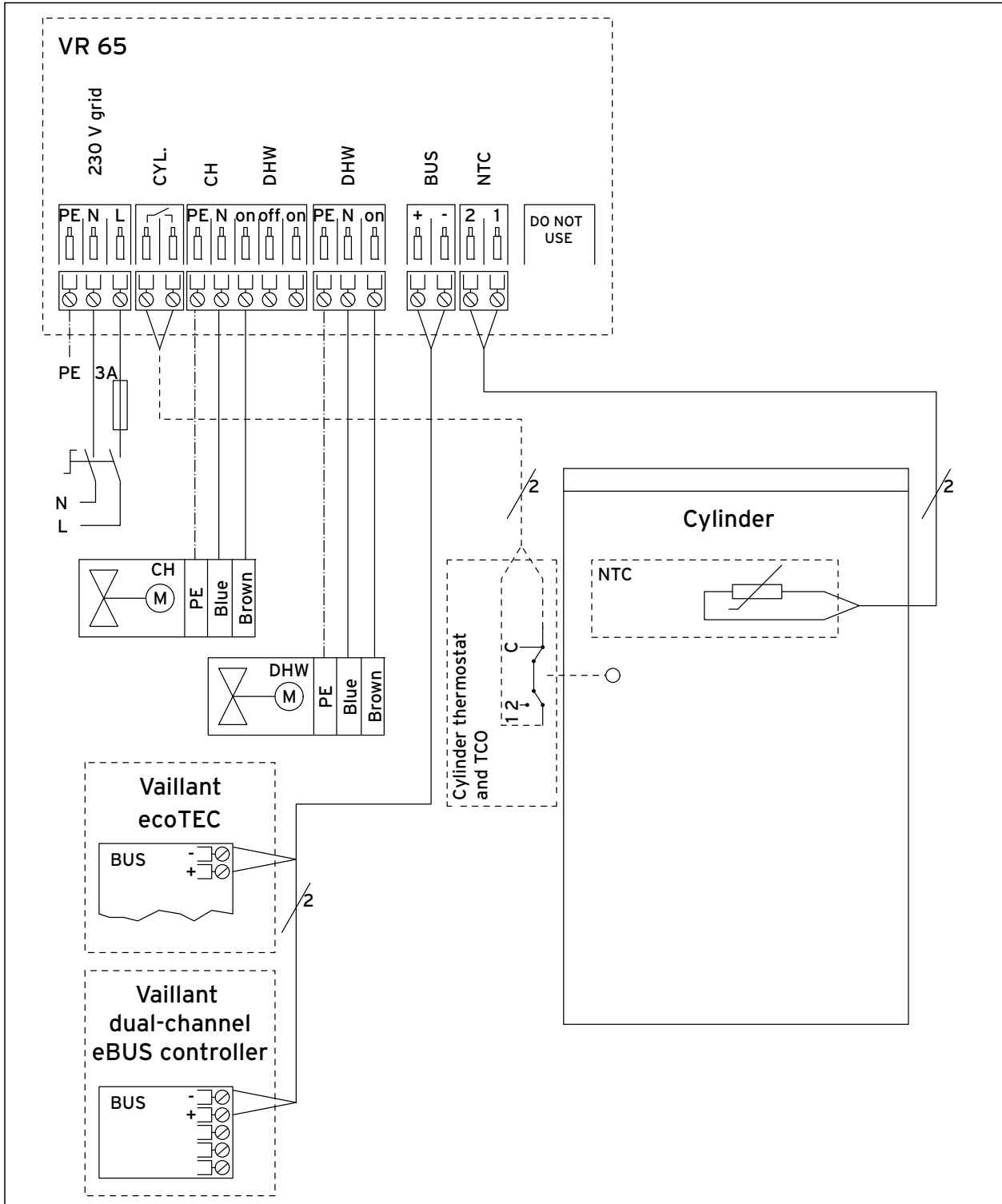

Fig. 5.10 Connection wiring diagram 1

- eBUS-compatible Vaillant gas-fired wall-hung boiler
 - Wiring via Control Center VR 65
 - Primary heating circuit control via Vaillant dual-channel eBUS controller
 - Room heating control via Vaillant dual-channel eBUS controller
 - S plan
- Next to the domestic hot water cylinder, install the Control Center VR 65.
 - Dismantle the cover of the VR 65.



The terminals **NTC** and **CYL.** of the VR 65 may not be connected at the same time.

Option 1: Temperature sensor (NTC) on VR 65:

- Insert the VR 10 temperature sensor delivered with the VR 65 into the immersion sleeve (**2 → fig. 5.7**) for the reheating circuit (NTC).
- Connect the temperature sensor (NTC) to the terminal **NTC** of the VR 65.

Option 2: Cylinder thermostat to VR 65:

- Dismantle the cover of the cylinder thermostat (**7 → fig. 5.7**).
- Connect the terminals **1** (cylinder thermostat) (**3 → fig. 5.8**) and **C** (reheating circuit TCO) (**5 → fig. 5.8**) to the terminal **CYL.** of the VR 65.
- Mount the cover for the cylinder thermostat.

The electrical installation of the eBUS connection is described in the installation instructions for the Vaillant dual-channel eBUS controller.

- Install the eBUS connection from the gas-fired wall-hung boiler to the Control Center VR 65.
- Install the eBUS connection from the gas-fired wall-hung boiler to the Vaillant dual-channel eBUS controller.

The electrical installation of the zone valves is described in the installation instructions for the VR 65.

- Connect the zone valves for the heating circuit and hot water circuit in accordance with connection diagram 1 (S plan hydraulics).
- Install the mains connection cable for the VR 65.
 - Mount the covers of the VR 65.
 - Connect the gas-fired wall-hung boiler and the VR 65 to the power mains.
 - Adjust the Vaillant dual-channel eBUS controller in accordance with its operating and installation instructions.

5 Installation

Connection wiring diagram 2 (Y plan)

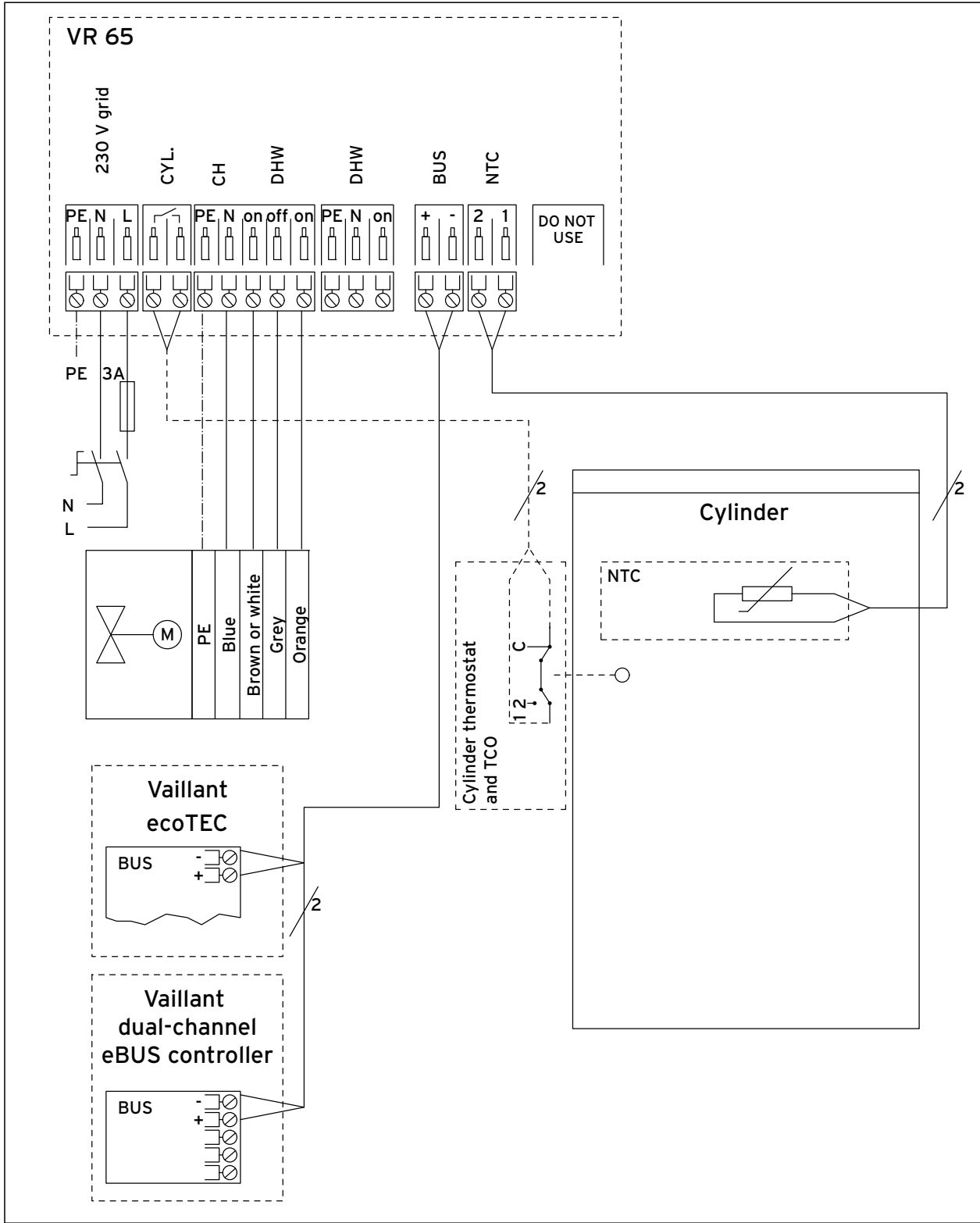

Fig. 5.11 Connection wiring diagram 2

- eBUS-compatible Vaillant gas-fired wall-hung boiler
- Wiring via Control Center VR 65
- Primary heating circuit control via Vaillant dual-channel eBUS controller
- Room heating control via Vaillant dual-channel eBUS controller
- Y plan



This type of installation is only permissible for boilers which comply with G3

- Next to the domestic hot water cylinder, install the Control Center VR 65.
- Dismantle the cover of the VR 65.



The terminals **NTC** and **CYL.** of the VR 65 may not be connected at the same time.

Option 1: Temperature sensor (NTC) on VR 65:

- Insert the VR 10 temperature sensor delivered with the VR 65 into the immersion sleeve (**2** → **fig. 5.7**) for the reheating circuit (NTC).
- Connect the temperature sensor (NTC) to the terminal **NTC** of the VR 65.

Option 2: Cylinder thermostat to VR 65:

- Dismantle the cover of the cylinder thermostat (**7** → **fig. 5.7**).
- Connect the terminals **1** (cylinder thermostat) (**3** → **fig. 5.8**) and **C** (reheating circuit TCO) (**5** → **fig. 5.8**) to the terminal **CYL.** of the VR 65.
- Mount the cover for the cylinder thermostat.

The electrical installation of the eBUS connection is described in the installation instructions for the Vaillant dual-channel eBUS controller.

- Install the eBUS connection from the gas-fired wall-hung boiler to the Control Center VR 65.
- Install the eBUS connection from the gas-fired wall-hung boiler to the Vaillant dual-channel eBUS controller.

The electrical installation of the zone valves is described in the installation instructions for the VR 65.

- Connect the 3-way valve for the heating circuit and hot water circuit in accordance with connection diagram 2 (Y plan hydraulics).
- Install the mains connection cable for the VR 65.
- Mount the covers of the VR 65.
- Connect the gas-fired wall-hung boiler and the VR 65 to the power mains.
- Adjust the Vaillant dual-channel eBUS controller in accordance with its operating and installation instructions.

Connect the cylinder to the standard cabling box (S plan or Y plan hydraulics)

The cylinder thermostat can be connected to S plan or Y plan hydraulics by means of standard cabling.

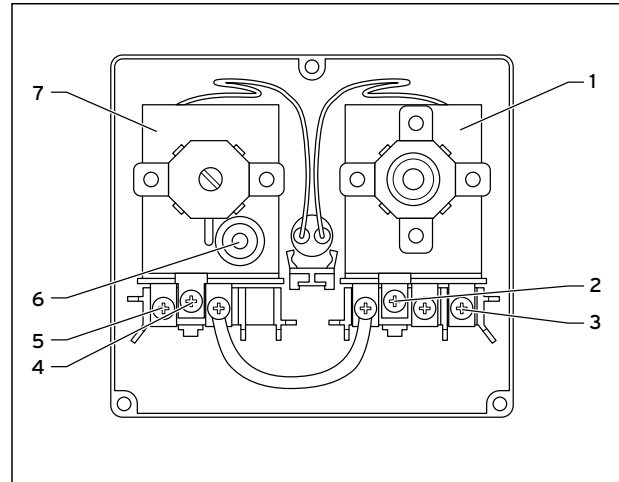

Fig. 5.12 Connections of the cylinder thermostat and the thermal cut-out

Key

- 1 Cylinder thermostat
- 2 Cylinder thermostat protective earth terminal
- 3 Cylinder thermostat terminal 1
- 4 Primary heating circuit TCO protective earth terminal
- 5 Primary heating circuit TCO C terminal
- 6 Primary heating circuit TCO reset button
- 7 Primary heating circuit thermal cut-out (TCO)

6 Commissioning

6.1 Flushing the reheating circuit

Detailed recommendations for the water circuit can be found in BS 6798 and BS 5449: Part 1 (for central heating systems with both small and the smallest pipe width).

Pipes which do not form part of the usable heating surface must be insulated in order to prevent heat losses and possible freezing. Pipe insulation is particularly important if you are installing pipes under the roof or in open areas under the floor.

Discharge valves must be mounted in easily accessible locations, so that the entire system, including the boiler and hot water system, can be discharged. Discharge valves must have a nominal size of 1/2 inch BSP and comply with BS 2879.

Copper pipes which comply with BS 2871: Part 1 for water-carrying pipes must be used. All soldered connections in the private hot water pipe system must be made with lead-free soldering material.



Caution!

Risk of material damage as a result of deposits in the unit or system!

Cleaning agents can result in deposits and follow-on damages.

- Use a suitable cleaning agent in accordance with this instruction manual.
- Never leave cleaning agents in the system for longer than 24 hours.
- Completely remove the cleaning agents from the system by flushing it thoroughly.

All cleaning must be performed before installing the new boiler and must comply with BS 7593. Information on the use of cleaning agents for the system can be obtained from Sentinel, Betz Dearborn Ltd. Widnes, Cheshire, WA8 8UD. Tel: 0151 420 9595, or Fernox, Alpha Fry Technologies, Tandem House, Marlow Way, Croydon, CR0 4XS. Tel: 0870 8700362.

6.2 Water treatment



Caution!

Risk of material damage due to unsuitable water!

Unsuitable water can lead to deposits and corrosion damage in the cylinder and in the hot water circuit.

- Use only potable water with a chloride content of below 250 mg/l in the hot water circuit.



Caution!

Risk of material damage as a result of enriching the heating water with unsuitable frost or corrosion protection agents!

Frost and corrosion protection agents can cause changes to the seals, noises during heating mode and possibly subsequent damage.

- Do not use any unsuitable frost and corrosion protection agents.

Mixing additives with the heating water can result in material damage. However no incompatibility with Vaillant units has been detected with proper use of the following products over a long period.

- When using additives, follow the manufacturer's instructions without exception.

Vaillant does not accept any liability relating to the compatibility or efficiency of any additives throughout the heating system

Additives for cleaning measures (subsequent flushing required)

- Fernox F3
- Jenaqua 200
- Jenaqua 300
- Jenaqua 400
- Sentinel X 300
- Sentinel X 400

Additives intended to remain permanently in the system

- Fernox F1
- Fernox F2
- Jenaqua 100
- Jenaqua 110
- Sentinel X 100
- Sentinel X 200

Additives for frost protection intended to remain permanently in the system

- Fernox Antifreeze Alphi 11
- Sentinel X 500

- Inform the operator of the necessary measures if you have used these additives.
- Inform the operator about the required measures for frost protection.
- Observe all valid national and technical regulations when treating the filling and supplementary water.

Provided the national regulations and technical standards do not stipulate more stringent requirements, the following applies:

- You must treat the heating water in the following cases:
 - If the entire filling and supplementary water quantity during the operating life of the system exceeds three times the nominal volume of the heating system or
 - If the limit values shown in the tables are not observed.

Total heating output	Overall hardness at smallest boiler heating surface ²⁾		
	20 l/kW	> 20 l/kW < 50 l/kW	> 50 l/kW
kW	mol/m ³	mol/m ³	mol/m ³
< 50	No requirement or < 3 ¹⁾	2	0,02
> 50 to ≤ 200	2	1,5	0,02
> 200 to ≤ 600	1,5	0,02	0,02
> 600	0,02	0,02	0,02

- 1) For systems with circulation water heaters and for systems with electric heating elements
- 2) Of specific system volume (nominal content in litres/heating output; in the case of multi-boiler systems, the smallest single heating output is to be used).
These values only apply up to 3 times the system volume for filling and supplementary water. Once this triple system volume is exceeded, the water will have to be treated exactly the same as in case of exceeding the limit values given in Table 6.1 (softening, desalination, hardness stabilisation and desludging).

Table 6.1 Guidelines for the heating water: Water hardness

Heating water characteristics	Unit	Low-salt	Saline
Electrical conductivity at 25 °C	µS/cm	< 100	100 - 1500
Appearance		Free from sedimentary materials	
pH value at 25 °C		8,2 - 10,0	8,2 - 10,0
Oxygen	mg/l	< 0.1	< 0.02

Table 6.2 Guidelines for the heating water: Salt content

6.3 Filling the cylinder



Use the draw-off points to vent the cylinder and water pipes. Do not use the combined temperature/pressure relief valve of the cylinder or the pressure relief valve of the cold water safety assembly for venting, since foreign bodies can contaminate or damage the valves.

- Make sure that the drain valve is closed.
- Open all of the draw-off points in the cold and hot water pipes.
- Open the water supply inlet to the cylinder and allow the water to run until bubble-free water runs from all of the draw-off points and the air is removed from the system.
- Close all of the draw-off points.
- Check the system for leaks.
In particular, check the installed electric immersion heater for leaks.
- Open two hot water draw-off points, one at the lowest point and one at the highest point of the pipe system, and allow water to run for at least 5 minutes.
- Close both of the hot water draw-off points.

6 Commissioning

6.4 Filling the central heating system

The system can be filled using the built-in filling loop (ecoTEC plus combi boiler only) or via a separate filling connection that is fitted at an easily accessible location in the heating circuit. The filling loop must be removed once filling is complete. If a temporary connection is not possible due to legal regulations, a closed system filling pump with a buffer tank must be used.

The heating system is not automatically supplied from the hot water side of the central heating. Alternative procedures for filling closed systems can be found in BS 5449.



Do not use the pressure relief valve of the gas-fired wall-hung boiler for venting.

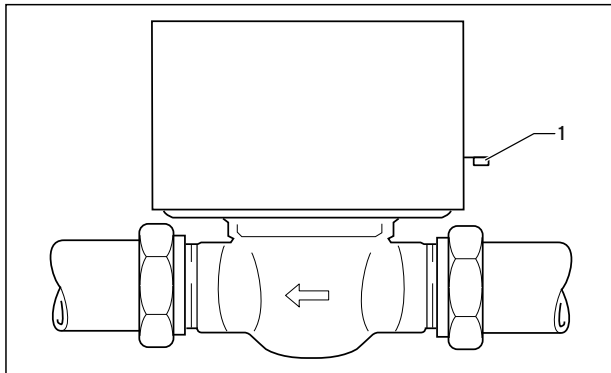

Fig. 6.1 Two port motorised valve

- Place the lever (1) on the two port motorised valve to "MAN OPEN" and lock it into this position.
- Flush the entire primary central heating system including the reheating circuit with cold and hot water.
- Flush, fill, and vent the central heating system in accordance with the installation instructions of the gas-fired wall-hung boiler.
- Release the lever on the two port motorised valve by placing it in the "AUTO" position.

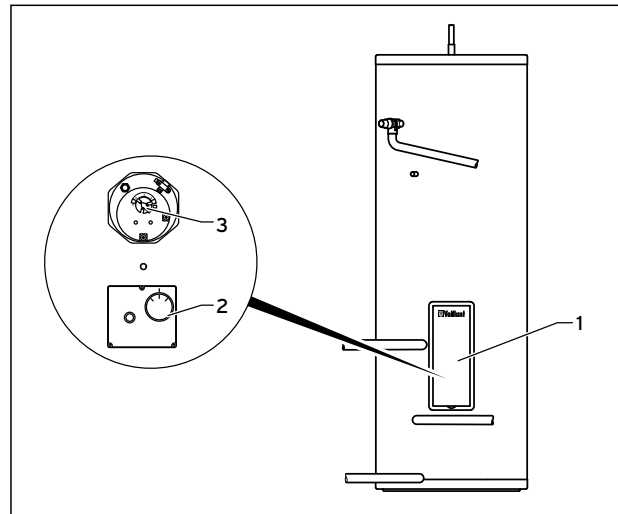

Fig. 6.2 Setting thermostats

- Remove the front cladding (1) from the cylinder.
- Dismantle the electric immersion heater cover.
- Place the cylinder thermostat (2) and the electric immersion heater thermostat (3) into the central position (around 45°C) for initial commissioning and to achieve maximum energy efficiency.
- Commission the gas-fired wall-hung boiler (→ **section 6.5**) until the cylinder reaches the operating temperature and all radiators in the system are hot.
- Then drain the entire central heating system again to remove any residue from the pipes.
- Fill and vent the entire central heating system again as described in the installation instructions for the gas-fired wall-hung boiler.

6.5 Commissioning the gas-fired wall-hung boiler

- Make sure that the control device and thermostats are set so that heating is required.
- Carry out the commissioning and testing measures for the gas-fired wall-hung boiler in accordance with the installation instructions.
- Check whether the gas-fired wall-hung boiler starts operating and the water in the cylinder and radiators heats up in accordance with the hot water and room thermostat settings.
- Following completion of the commissioning procedure, use the controller to set the hot water temperature to a maximum of 60°C in order to achieve the highest degree of energy efficiency. If you are controlling the hot water temperature via the cylinder thermostat installed in the cylinder, switch the cylinder thermostat (2) on. Set the electric immersion heater thermostat (1) to the required temperature.
- Reattach the cover for the electric immersion heater and the upper front cladding of the cylinder.
- Regulate the hot water thermostat mixer via the adjusting knob to maintain the required temperature on the hot water taps.

6.6 Filling in the cylinder commissioning checklist

- Fill in the benchmark cylinder commissioning checklist located on the last few pages of these instructions.

6.7 Handover to the operator

You must brief the operator of the unit on the handling and function of the cylinder.

- Provide the operator with all relevant instructions and unit documentation.
- Go through the operating instructions with the operator and answer any questions.
- Draw special attention to the safety instructions which the operator must follow.
- Inform the operator of the necessity of ensuring the regular inspection/maintenance of the system (inspection and maintenance contract).
- Make the operator aware that the instructions must be kept near to the cylinder and must be accessible to anyone working on the cylinder.
- Inform the operator of the correct (efficient) settings for temperatures, controllers, and thermostatic radiator valves.
- Explain to the operator how to safely use the cylinder and control devices.
- Inform the operator of the required precautionary measures to prevent damage to the system and building if the system is not kept in operation during frost.
- In addition, inform the operator that the electric immersion heater is intended as a reserve appliance for water heating and must not be used to heat water in the cylinder at the same time as the gas-fired wall-hung boiler.



In regions with hard water, the set hot water temperature must not exceed 60°C to avoid scaling.

For more information, contact Vaillant customer service.

7 Inspection and maintenance

7 Inspection and maintenance

Regular inspections and maintenance of the cylinder by a competent person approved at the time by the Health and Safety Executive are a prerequisite for long-lasting operational readiness, reliability and a long working life. The operational reliability of the cylinder may be impaired and material damage and personal injuries may result if the inspection and maintenance work is not carried out.

The essential maintenance work on the cylinder and the corresponding maintenance intervals are specified in the table below.



When replacing parts, use only original replacement parts from Vaillant Ltd.

Replacement parts

An overview of the available genuine Vaillant replacement parts can be obtained from your wholesaler (replacement parts catalogue, printed or on CD-ROM).

Maintenance work on	Maintenance interval
Cylinder	
Check all connections to ensure that there are no leaks.	Annually
Check the temperature and pressure relief valve.	Annually
Check the expansion relief valve.	Annually
Check the charge pressure of the hot water expansion vessel.	Annually
Check water flow rates are correct (check and clean filters as necessary)	Annually
Ensure set temperatures are correct	Annually
Check the charge pressure of the expansion vessel, re-pressurise as necessary	Annually
Fill in the service section of the Benchmark cylinder commissioning checklist.	Annually

Tab. 7.1 Maintenance checklist

7.1 Checking the temperature and pressure relief valve and expansion relief valve

- Open each valve manually by turning the valve cap and check whether water is able to flow to the drain via the tundish without obstruction. Make sure that both valves sit correctly in their idle position.

7.2 Checking the charge pressure of the expansion vessel

- Shut off the water supply pipe and open the nearest hot water draw-off point to discharge the pressure from the secondary water system.
- Use a pressure gauge to check the expansion vessel pressure at the measuring point. If the pressure is below 3.0 bar, increase it using a suitable air pump.
- Fill in the maintenance section of the commissioning report.

7.3 Draining the cylinder

- Close the cold water supply pipe.
- Secure a hose to the drain valve.
- Place the free end of the hose in a suitable discharge position. The opening should be around 1 m beneath the cylinder.
- Open the highest hot water draw-off point to reduce the pressure and vent the water pipes, thus draining them completely.
- Open the cylinder drain valve and leave open until no more water escapes and the cylinder is completely empty.
- Once the water has drained out, close the hot water draw-off point and the drain valve.
- Remove the hose from the drain valve.

8 Fault finding

The tables below provide information on possible faults which can occur when the cylinder is being operated along with information on their causes and how to rectify them.

All work on the Vaillant cylinder (installation, maintenance, repairs etc.) may only be performed by competent persons.

**Danger!****Risk of death from electric shock!**

Improperly executed work on the cylinder can result in a risk to life and limb.

- Faults may only be eliminated by a competent person approved at the time by the Health and Safety Executive.

**Caution!****Risk of damage due to overheating!**

Not all electric immersion heaters have a thermal cut-out.

- Use only Vaillant Ltd. electric immersion heaters with a thermal cut-out as replacement parts.



When replacing parts, use only original replacement parts from Vaillant Ltd.

We recommend entering into a maintenance agreement.

8 Fault finding

Fault	Cause	Remedy
The cylinder cools down at night.	One-pipe circulation in the case of short tube networks with low pressure loss.	Install a non-return valve (as close as possible to the cylinder).
Primary heating is not working. The gas-fired wall-hung boiler runs for a short time, goes off, and then comes back on again. This is repeated until the cylinder is at its target temperature.	1. Air in the reheating heat exchanger.	Vent the reheating heat exchanger.
	2. Heat exchanger surface area too small.	Compare the data provided by the boiler manufacturer with the data for the cylinder. It may be possible to solve the problem by setting a higher flow temperature on the gas-fired wall-hung boiler.
Only cold or lukewarm water comes out of the draw-off points.	1. The cold and hot water draw offs on the cylinder have been mixed up.	Turn off the cold water supply, then let water flow out via the hot water draw off. Only a few litres of water flow out if the connection is set up correctly. The hot water withdrawal pipe intake is then in the air space and further draining is not possible. If it is possible to empty the entire cylinder via the hot water draw off, the connections have been laid incorrectly. Change the connections!
	2. Hot water thermostat mixer set too low.	Increase the setting.
	3. Heating insufficient; gas-fired wall-hung boiler does not reheat. External control device faulty.	Check whether the gas-fired wall-hung boiler is working. Check whether the external control device is working. Check that the two port valve is in the DHW position. Replace the two port valve. Vent the reheating heat exchanger.
	Air in the reheating heat exchanger. Cylinder sensor faulty.	Check the thermal cut-out and repair the fault. Replace the cylinder thermostat.
Water flows out of the expansion relief valve (only when heating up).	Dirt on the valve seat of the expansion relief valve.	Check the seat of the expansion relief valve and repair the fault.
	Pressure reducing valve faulty.	Check whether the pressure behind the pressure reducing valve is lower than 3.0 bar. If so, replace the pressure reducing valve.
	Expansion vessel faulty.	Check the pressure in the expansion vessel. If the pressure is insufficient, re-establish the pressure and check whether the expansion vessel maintains it.
	Expansion relief valve faulty.	If the pressure is normal, replace the expansion relief valve.
Water flows out of the temperature and pressure relief valve (only when heating up).	Dirt on the valve seat of the temperature and pressure relief valve.	Check the seat of the temperature and pressure relief valve and repair the fault.
	The temperature control system for the gas-fired wall-hung boiler is faulty.	If water is only escaping when being heated up by the gas-fired wall-hung boiler, check the temperature control system of the gas-fired wall-hung boiler. Check whether the two port valve switches to the heating position when the cylinder temperature is reached.
	Cylinder sensor faulty.	Check the cylinder sensor and corresponding thermal cut-out, replace the cylinder sensor if necessary, and repair the thermal cut-out fault.
	Temperature and pressure relief valve faulty.	If water is only escaping when being heated up by the electric immersion heater, replace the temperature and pressure relief valve.
	Electric immersion heater faulty.	Check the temperature sensor of the electric immersion heater and the corresponding thermal cut-out and replace the electric immersion heater if necessary.

Table 8.1 Troubleshooting

9 Taking the cylinder out of service

9.1 Temporarily taking the cylinder out of service



Caution!
Risk of damage as a result of the cylinder freezing!

Frost protection and monitoring devices are only active while the boiler is connected up to the power supply.

- Make sure that the cylinder cannot be damaged if there is a frost.

- Temporarily take the cylinder out of service by switching the boiler off.

9.2 Permanently taking the cylinder out of service



Danger!
Risk of death from electric shock from live connections!

There is continuous voltage present on the mains connection terminals of the boiler.

- Interrupt the power supply.
- Prevent the power supply from being switched on again.
- Ensure that any electrical work is carried out by a qualified competent person.

- Switch the boiler off.
- Drain the cylinder (→ **section 7.3**).
- Dismantle the hydraulic connections.
- Dismantle the temperature sensor.
- Remove the wiring for the temperature sensor from the boiler or external controller.

10 Recycling and disposal

Both the cylinder and its transport packaging are made primarily of recyclable raw materials.

10.1 Cylinder disposal

You must not dispose of the cylinder or any of its accessories in normal domestic rubbish.

- Dispose of the old unit and any accessories properly and in accordance with national regulations.

10.2 Disposal of packaging

The heating specialist company which installs the unit is responsible for disposing of the transport packaging.

- Observe national regulations.

11 Customer service and manufacturer's guarantee

11 Customer service and manufacturer's guarantee

11.1 Vaillant service

To ensure regular servicing, it is strongly recommended that arrangements are made for a Maintenance Agreement. Please contact Vaillant Service Solutions (0870 6060 777) for further details.

11.2 Vaillant warranty

Vaillant provide a full parts and labour warranty for this appliance - please see warranty card for details.

The appliances must be installed in accordance with The Water Regulations of:
England and Wales
Water (supply and fittings) Regulations 1999 within England and Wales or
Scotland
The Water Byelaws
Eire
Compliance with IS standards and Local Council regulations

Compliance with the Building regulations:
England and Wales
Scotland
Northern Ireland
Eire

Terms and conditions apply to the warranty, details of which can be found on the warranty registration card included with this appliance.

Failure to install and commission this appliance in compliance with the manufacturer's instructions may invalidate the warranty (this does not affect the customer's statutory rights).

Commissioning checklist and service record



SERVICE RECORD

It is recommended that your hot water system is serviced regularly and that the appropriate Service Record is completed.

Service Provider

Before completing the appropriate Service Record below, please ensure you have carried out the service as described in the manufacturer's instructions.

SERVICE 1 Date _____
Engineer Name _____
Company Name _____
Telephone Number _____
Comments _____

Signature _____

SERVICE 2 Date _____
Engineer Name _____
Company Name _____
Telephone Number _____
Comments _____

Signature _____

SERVICE 3 Date _____
Engineer Name _____
Company Name _____
Telephone Number _____
Comments _____

Signature _____

SERVICE 4 Date _____
Engineer Name _____
Company Name _____
Telephone Number _____
Comments _____

Signature _____

SERVICE 5 Date _____
Engineer Name _____
Company Name _____
Telephone Number _____
Comments _____

Signature _____

SERVICE 6 Date _____
Engineer Name _____
Company Name _____
Telephone Number _____
Comments _____

Signature _____

SERVICE 7 Date _____
Engineer Name _____
Company Name _____
Telephone Number _____
Comments _____

Signature _____

SERVICE 8 Date _____
Engineer Name _____
Company Name _____
Telephone Number _____
Comments _____

Signature _____

SERVICE 9 Date _____
Engineer Name _____
Company Name _____
Telephone Number _____
Comments _____

Signature _____

SERVICE 10 Date _____
Engineer Name _____
Company Name _____
Telephone Number _____
Comments _____

Signature _____

Supplier

Vaillant Ltd

Vaillant House ■ Medway City Estate ■ Trident Close ■ Rochester ■ Kent ME2 4EZ
Telephone 01634 292300 ■ Fax 01634 290166 ■ www.vaillant.co.uk ■ info@vaillant.co.uk

Manufacturer

Vaillant GmbH

Berghauser Str. 40 ■ D-42859 Remscheid ■ Telefon 0 21 91/18-0
Telefax 0 21 91/18-28 10 ■ www.vaillant.de ■ info@vaillant.de